

Errata

Title & Document Type: 6825A Bipolar Power Supply/Amplifier Operating and Service Manual

Manual Part Number: 06825-90001

Revision Date: March 1974

HP References in this Manual

This manual may contain references to HP or Hewlett-Packard. Please note that Hewlett-Packard's former test and measurement, semiconductor products and chemical analysis businesses are now part of Agilent Technologies. We have made no changes to this manual copy. The HP XXXX referred to in this document is now the Agilent XXXX. For example, model number HP8648A is now model number Agilent 8648A.

About this Manual

We've added this manual to the Agilent website in an effort to help you support your product. This manual provides the best information we could find. It may be incomplete or contain dated information, and the scan quality may not be ideal. If we find a better copy in the future, we will add it to the Agilent website.

Support for Your Product

Agilent no longer sells or supports this product. You will find any other available product information on the Agilent Test & Measurement website:

www.tm.agilent.com

Search for the model number of this product, and the resulting product page will guide you to any available information. Our service centers may be able to perform calibration if no repair parts are needed, but no other support from Agilent is available.



**BIPOLAR
POWER SUPPLY/AMPLIFIER
MODEL 6825A**

**OPERATING AND SERVICE MANUAL
FOR SERIALS 1324A-00101 AND ABOVE***

***For Serials Above 1324A-00101
a change page may be included.**

HEWLETT-PACKARD

TABLE OF CONTENTS

SECTION		PAGE
I	GENERAL INFORMATION	1-1
	1-1 Description	1-1
	1-3 Power Supply Features	1-1
	1-7 Amplifier Features	1-1
	1-10 Meters	1-1
	1-12 Specifications	1-1
	1-14 Options	1-5
	1-16 Accessories	1-5
	1-18 Instrument Identification	1-5
	1-21 Ordering Additional Manuals	1-5
II	INSTALLATION	2-1
	2-1 Initial Inspection	2-1
	2-3 Mechanical Check	2-1
	2-5 Electrical Check	2-1
	2-7 Repackaging for Shipment	2-1
	2-9 Installation Data	2-1
	2-11 Location	2-1
	2-13 Outline Diagram	2-1
	2-15 Rack Mounting	2-1
	2-17 Input Power Requirements	2-2
	2-20 Power Cable	2-2
III	OPERATING INSTRUCTIONS	3-1
	3-1 Introduction	3-1
	3-3 Rear Terminals and AC Input	3-1
	3-5 Operating Controls and Indicators	3-1
	3-6 Mode Switch	3-1
	3-10 Range Switch	3-2
	3-12 Voltage Control	3-2
	3-14 Current Control	3-2
	3-16 Voltage Metering	3-3
	3-18 Current Metering	3-3
	3-20 Turn-on Checkout Procedures	3-3
	3-22 Operating Modes	3-4
	3-24 Local Programming	3-4
	3-29 Operation of Supply Beyond Rated Output	3-5
	3-31 Reactive Load Considerations	3-5
	3-33 Connecting Load	3-5
	3-37 Remote Sensing	3-5
	3-40 Remote Programming	3-6
	3-53 Series and Parallel Connections	3-9
	3-57 Auto-Series and Auto-Parallel Connections	3-10
	3-62 Bipolar Overvoltage and Overcurrent Limit	3-11
	3-64 Reverse Voltage and Current Loading	3-11

TABLE OF CONTENTS (Continued)

SECTION		PAGE
IV	PRINCIPLES OF OPERATION	4-1
	4-1 Overall Description.....	4-1
	4-2 General	4-1
	4-4 Block Diagram Description	4-2
	4-15 Constant Voltage/Constant Current Operation	4-3
	4-18 Detailed Circuit Descriptions	4-4
	4-19 General	4-4
	4-21 Output Power Amplifier Circuits (Figure 7-2, Sheet 1).....	4-4
	4-40 Voltage and Current Control Circuits (Figure 7-2, Sheet 2).....	4-6
V	MAINTENANCE	5-1
	5-1 Introduction	5-1
	5-3 Test Equipment Required	5-1
	5-5 Performance Test	5-2
	5-7 Power Supply Mode Tests	5-2
	5-42 Constant Current Tests	5-8
	5-56 Amplifier Mode Tests	5-12
	5-60 Troubleshooting.....	5-13
	5-61 General	5-13
	5-64 Overall Trouble Isolation Procedure.....	5-13
	5-71 A2 Board Troubleshooting.....	5-19
	5-76 A3 Board and Heat Sink Assembly Troubleshooting.....	5-19
	5-82 Degraded Performance Problems.....	5-20
	5-84 Repair and Replacement	5-21
	5-86 Covers and Front Panel	5-21
	5-92 Rear Heat Sink Assembly	5-22
	5-98 Adjustment and Calibration	5-23
	5-100 Meter Zero	5-23
	5-102 Constant Voltage Calibration	5-23
	5-106 Constant Current Calibration	5-24
	5-109 AC Meter Calibration	5-24
VI	REPLACEABLE PARTS.....	6-1
	6-1 Introduction.....	6-1
	6-3 Ordering Information.....	6-1
VII	CIRCUIT DIAGRAMS.....	7-1
	7-1 Introduction.....	7-1
	7-3 Simplified Schematic Diagram.....	7-1
	7-5 Component Location Illustrations	7-1
	7-7 Schematic Diagrams	7-1

MANUAL CHANGES
 Model 6825A DC Power Supply
 Manual HP P/N 06825-90001
 02/25/97

Make all corrections in the manual according to errata below, then check the following table for your power supply serial number and enter any listed changes(s) in the manual.

CHANGE 1:

SERIAL		MAKE
Prefix	Number	
All	---	Errata
1324A	00106-00125	1
1517A	00126-00140	1-2
1606A	00141-00150	1-3
1612A	00151-00320	1-4
1808A	00321-00335	1-5
1818A	00336-00735	1-6
2048A	00736-00815	1-7
2125A	00816-00865	1-8
2142A	00866-00920	1-9
2229A	00921-01000	1-10
2312A	01001-01110	1-11,14*
2416A	01111-01150	1-12,14*
2437A	01151-01480	1-14
2833A	01481-01490	1-15
2844A	01491-01695	1-16
3115A	01696-01810	1-17
3349A	01811-01825	1-18
3511A	01826-01835	1-19
3514A	01841-01845	1-20
3544A	01846-01850	1-21
3603A	01851-01865	1-22
3645A	01866-01875	1-23
3645A	01876-01880	1-24
3713A	01881-up	1-24

ERRATA:

In paragraph 2-19, change the last sentence to read "Make sure that the correct fuse is installed if the position of the slide switch is changed (1A for 115 V operation, and .5 A for 230 V operation). In paragraph 3-4, change the third sentence to read "The power module contains fuse F1 (1A for 115 Vac or .5 A for 230 Vac) and a slide switch for connecting 115Vac or 230Vac input power to the instrument.

In Figure 3-14, the -V, +I quadrant should read "SINK". Change paragraph 7-4, to read "Figure 7-1 shows the relationship between the instrument assemblies and ties the schematic diagram sheets together."

Add the following to the Option No. 007 (ten-turn Option Voltage Control) description in paragraph 1-15 "Shunt resistor A1R53 and standard VOLTAGE control (HP P/N 2100-3272) A5R2 are removed when the ten-turn output voltage control (HP P/N 2100-1867) is installed in the A5R2 location."

In Table 1-1 make the following changes: Under General Specifications, change meters paragraph to read: "Individual voltage and current meters. DC voltmeter accuracy is +3% of full scale. AC voltmeter accuracy is +/-5% of full scale with sinusoidal, 100 Hz input. AC and DC ammeter accuracy is +6% of full scale."

Under Power Supply Specifications change load effect (load regulation) to read:

Voltage (X1 Range): 0.01% + .5 mV
 Voltage (X4 Range): 0.01% + 1mV

Change Source Effect (line regulation) to read:

Voltage (X1 Range): 0.01% + .5 mV

Change PARD (Ripple and Noise) to read:

Voltage (X1 Range): 3 mV rms/8 mV p-p
 Voltage (X4 Range): 10 mV rms/30 mV p-p

Current: 5 mA rms/15 mA p-p

Under Power Amplifier Specifications add the following to the Distortion Specification: Total harmonic distortion (THD) at full output is as follows:

FREQ.	THD
100 Hz	.08%
1 kHz	.1%
10 kHz	.35%
20 kHz	1.5%
30 kHz	2.2%
40 kHz	5%

In paragraph 5-12 change voltage specified in step (q) and (u) to "1.0 mV".

In paragraph 5-14 change voltage specified in steps (f) and (h) to "3 mV".

In paragraph 5-14 change voltage specified in steps (k) and (m) to "1.0 mV".

In paragraph 5-25 step (c) change the ripple and noise values to:

X1 Range: 3 mV rms/8mV p-p
 X4 Range: 10 mV rms/30 mV p-p

In paragraph 5-27 change data after step (e) to:

X1 Range: 4 mV p-p instead of 8 mV p-p
 X4 Range: 15 mV p-p instead of 30 mV p-p

In paragraph 5-58 change frequency specified in step (e) to "40 kHz".

Add step (f) to paragraph 5-59 as follows: f. The maximum THD at other frequencies can be measured in a similar manner. (See Table 1-1 for THD percentages). Change steps (g) and (i) of paragraph 5-107 to read as follows: g. Momentarily remove the load and adjust front panel + IZERO ADJ (A1R2) so that the CURRENT MODE light goes out. Reconnect load and adjust A1R2 for a DVM reading of +.7 to +1.0 mV. h. Turn VOLTAGE control fully counterclockwise. i. Momentarily remove the load and adjust front panel -I ZERO ADJ (A1R3) so that the CURRENT MODE light goes out. Reconnect load and adjust A1R3 for a DVM reading of -.7 to 1.0 mV.

Change steps (a) and (b) of paragraph 5-108 to read as follows: a. Set CURRENT METER switch to the .24 A DC position. b. Adjust A1R20 for a front panel ammeter indication of .2 A.

Change steps (a) through (c) of paragraph 5-111 as follows: a. Connect DVM across the 1 ohm resistor. Set the CURRENT METER switch to the .16 A ac position b. Adjust function generator output level for a DVM reading of .14 +0.6 V rms. c. Adjust A1R18 for a .14 A rms on front panel ammeter.

In the Replaceable Parts Table and on the schematic, make the following changes: Under A2 voltage and current control plug-in board: Delete: CR5 diode HP P/N 1901-0050. VR5 zener diode, HP P/N 1902-1221. VR6 zener diode, HP P/N 1902-0064. Change: C7 to fxd, mica, 4300pF 500 V, HP P/N 0160-2036.

Under A1 Interconnect and Power Supply Board: Change: R9 to fxd, film 2.15 k +1%, 1/8 W, HP P/N 0698-0084. R10 to fxd, film, 3.32 k +1%, 1/8 W, HP P/N 0757-0433. R11 to fxd, film, 36.5 k +1%, 1/8 W, HP P/N 0757-0455. R14 to fxd, film, 1 k +1%, 1/8 W, HP P/N 0757-0280. R15 to fxd, film, 178 +1%, 1/8 W, HP P/N 0698-3439. R16 to fxd, film, 9 k +1%, 1/8 W, HP P/N 0698-5454. R17 to fxd, film, 825 +1%, 1/8 W, HP P/N 0757-0421. R19 to fxd, film, 900 +1%, 1/8 W, HP P/N 0757-1099. R21 to fxd, film, 2.15 k +1%, 1/8 W, HP P/N 0698-0084.

R22 to fxd, film, 34.8 +1%, 1/8 W, HP P/N 0698-3434. R23 to fxd, film, 499 +1%, 1/8 W, HP P/N 0698-4123. R24 to fxd, film, 6 k +1%, 1/8 W, HP P/N 0698-3476. R58 to fxd, film, 750 +1%, 1/8 W, HP P/N 0757-0420.

On Sheet 1 of Figure 7-2: Connect resistor A1R15 (178 ohms 1/8 W) between A1S1C pin 12 and A1S1B pin 4.

CHANGE 2:

This change improves transient response by eliminating oscillations in the CV/CC crossover region.

In the Replaceable Parts Table and on the Voltage and Current Control Circuits schematic, make the following changes: Under A2 Voltage and Current Control Plug-In Board: Delete: CR9 diode, HP P/N 1901-0460. Q1, transistor, HP P/N 1854-0071. Change: R74 to 5.11 k 1%, 1/8 W, HP P/N 0757-0438.

Make above changes in Current Comparison Amplifier Circuit the on schematic diagram.

ERRATA:

In the Replaceable Parts Table, under Front Panel-Mechanical change part number of clip, quantity 4, to 1400-0547.

These changes affect the current meter circuit on the A1 board. Correct the parts list and Sheet 1 of the Figure 7-2 schematic as follows: Change A1R21 to 2.4 k ohm, HP P/N 0698-4435 (the value of A1R21 must be selected for optimum performance). Change A1R22 to 100 ohm, HP P/N 0757-0401. Delete A1R19.

Replace the DC ammeter calibration procedure of paragraph 5-108 with the following: a. Turn off BPS/A. Remove the 10.24 k ohm resistors and replace the jumpers from A20 to A21 and from A13 to A14. Ensure that jumpers are also from A12 to A13 and from A19 to A21. Adjust the CURRENT control for an output of 0.20 A. b. Set the CURRENT meter switch to 0.24 A DC position. c. Adjust A1R20 for a front panel ammeter indication of 0.20A.

CHANGE 3:

In replaceable parts list, under A1 Interconnect and Power Supply Board-Mechanical, add heat dissipator (qty. 4) CR12-CR15, HP P/N 1205-0030.

CHANGE 4:

In the Replaceable parts table, make the following changes: Under A4 Power Module: Change A4 Power Module to HP P/N 0960-0444. Under Chassis-Mechanical: Change HP P/N of the bottom rear panel to 5000-3129. Replace paragraphs 2-18 and 2-19 with the following: 2-18 Model 6825A may be operated continuously from a nominal 100 V, 120 V, 220 V, or 240 V (48-63 Hz) power source. A printed circuit board located within the ac power module on the rear panel selects the power source. Voltage choices are available on both sides of the PC board. Before connecting the instrument to the power source check that the PC board selection matches the nominal line voltage of the source. The operating voltage is shown in the window of the ac power module. If required, select the proper voltage as follows (refer to Figure 2-2): a. Remove power cable from instrument. b. Move plastic door on power module aside. c. Rotate FUSE PULL to the left and remove line fuse F1. d. Remove PC board from slot. Select operating voltage by orienting PC board to position the desired voltage on top-left side of PC board. Push board firmly into slot. e. Rotate FUSE PULL back into normal position and re-insert fuse F1 in holder using caution to select the correct value for F1 (1A slo-blow for 100 V or 120 V and 0.5 A slo-blow for 220 V or 240 V). f. Close plastic door and connect power cable.

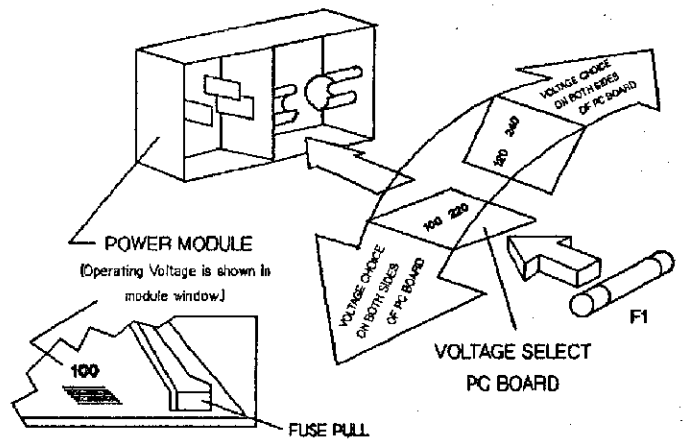
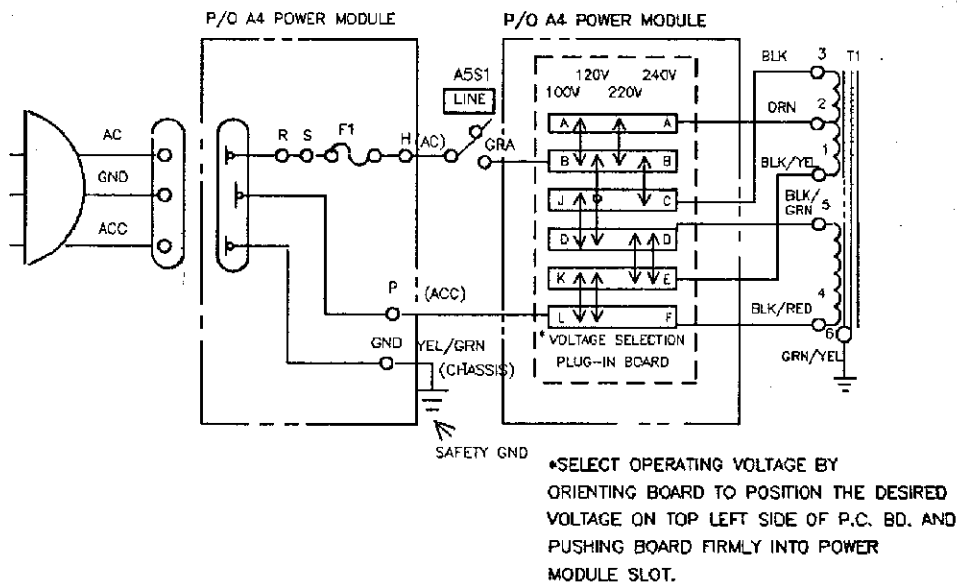

Figure 2-2. Line Voltage Selection

2-19 When the instrument leaves the factory, a 1A fuse is installed for 120 V operation. An envelope containing a 0.5 A fuse for 220 V/240 V operation is attached to the instrument. Make sure that the correct fuse value for F1 is installed if the position of the PC board is changed.

Change the schematic, Figure 7-2, (Sheet 1), to illustrate the new A4 Power Module (0960-0444) as shown below.

Add the following to the "Ordering Additional Manuals" paragraph in Section I: Extra manuals may be obtained by specifying Option 910 when ordering your instrument. The number of extra manuals depends upon the quantity of Option 910's ordered."



ERRATA:

When using a programmable resistance card installed in a 6940B Multiprogrammer to program the PS/A, it is possible to generate spikes at the PS/A's output unless its output is held at the former value until a new value has been programmed. An internal relay operated by a control voltage applied between terminals A15 and A16 disconnects the input to the voltage comparison amplifier and momentarily opens its dc feedback loop when it is energized. A capacitor in the circuit holds the amplifier's output voltage relatively constant during the 8 milliseconds the relay contacts are open during the transfer. It is normal for the PS/A's output to drift 300 to 500 millivolts during this time. If drift is greater than this amount, try adjusting A1R61 slightly while repetitively programming the PS/A until the drift is minimized. If the setting of A1R61 must be changed by more than a slight amount, the PS/A will then need to be recalibrated following the procedure of paragraph 5-103.

Effective January 1st, 1977, Option 007 (10-turn voltage control) has been redesignated Option 009. Make this change wherever Option 007 is mentioned in the manual.

Change Section 2-19 to read as follows:

The power supply may be operated from either a nominal 115 volt or 230 volt 48-63 Hz power source. When the instrument leaves the factory, the proper internal/external voltage selection, line cord plug, and fuse have been installed to operate with the mains voltage, frequency, and outlet receptacle of the country of destination. Make sure that the correct fuse is installed if the mains voltage is changed.

In the parts list, page 6-5, change A1R8 and A1R13 to resistor variable, 5 k, 1/2 W, 10%, cermet, HP P/N 2100-3252, qty 2. On page 6-10, delete Terminal Block, TQ 3, HP P/N 0360-1766, and in its place added Terminal Block, TQ 3, HP P/N 0360-2161. On page 6-11, change the Top cover to HP P/N 5000-9367 qty 1.

CHANGE 5:

The serial prefix number has been changed to 1808A. This is the only change.

CHANGE 6:

In the parts list, page 6-11, delete heat sink HP P/N 5020-8401. Add heat sink (left side), HP P/N 5020-2583 and heat sink (right side), HP P/N 5020-2584.

CHANGE 7:

In the parts list, page 6-5 change K1 relay to 6 V AC/DC HP P/N 0490-1298.

CHANGE 8:

In the parts list, page 6-9 and on schematic Figure 7-2 (Sheet 1), change A3C15 to 0.2 uF, 100 V, HP P/N 0160-0818.

CHANGE 9:

On page 4-5 paragraph 4-36, change reference designator R37 to R72. In paragraph 4-37 change the first sentence to read: At turn off, the +20 V (unfiltered) supply voltage is removed and relay A1K1 is deenergized.

In the parts list under A1 Interconnect and Power Supply Board:

- Delete: R32 fxd 1.3k .25W HP P/N 0757-0735
- Add: R72 fxd 18k .5W HP P/N 0686-1835
- R73 fxd 5.1k .5W HP P/N 0686-5125
- CR21 Diode Si 200 prv HP P/N 1901-0327
- VR4 Diode zener 11.8V HP P/N 1902-3180
- Change: C2 to 3.3 uF 15V HP P/N 0180-2264
- CR4 to SCR HP P/N 1884-0074
- R37 to 390 ohm 3W HP P/N 0811-1799

In Figure 7-2 Sheet 1, change the schematic as follows:

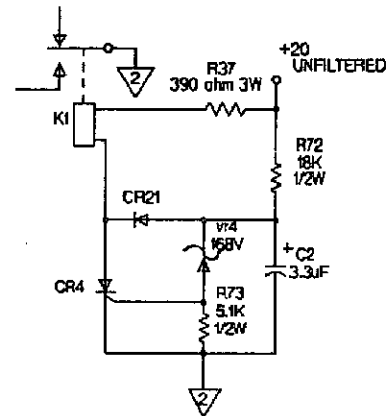

In the replaceable parts table page 6-5 and on the schematic Figure 7-2 Sheet 1, change R21 to 2.61 k 1/8 W HP P/N 0698-0092 (the value of R21 must be selected for optimum performance). This change supersedes the Errata change made on page 2.

CHANGE 10:

In the replaceable parts list on page 6-5, change R1, 2, 3, to var, ww, 100, 10% HP P/N 2100-3349. On page 6-11, under Front Panel-Mechanical, change output Panel to HP P/N 5000-3189.

CHANGE 11:

In the replaceable parts list, page 6-10, under A5 Front Panel-Electrical, delete R2 var, ww, 25 k, 5%, 2 W, HP P/N 2100-3272 and add R2 var, ww, 20 k, 5% 2 W, qty. 1. Also, on page 6-11, under Front Panel-Mechanical, delete Knob, pointer, HP P/N 0340-1090, qty. 1., and add HP P/N 0370-1091, qty. 1. On page 6-6 delete R53 HP P/N 0698-5092. This change obsoletes Option 009.

CHANGE 12:

On page 1-2, Table 1-1, change the Resolution Spec. for Voltage (X1 Range) to 4mv, and (X4 Range) to 16mv.

CHANGE 13:

In the replaceable parts list page 6-10, below S1, add HP P/N 5001-6715, polimide paper insulator, qty 1. The insulator is installed over S1.

*CHANGE 14:

This change is retroactive starting with prefix-serial number 2312A 01001-01110.

On page 1-3, Table 1-1 Specifications, change the Remote Resistance Programming Coefficient as follows:

Voltage (X1 Range): 2000ohms/V (typical)

Voltage (X4 Range): 500ohms/V (typical)

On page 5-23 add the following NOTE and steps to paragraph 5-104.

This procedure should be followed to achieve optimum accuracy when programming with an external resistance. This procedure may not allow full scale voltage adjustment when using the front panel VOLTAGE control (10 turn potentiometer A2R5) on units with a serial prefix of 2315A and up. To adjust units with serials prefixed 2315A and up, or any unit with a 10-turn potentiometer for the voltage control, follow steps i and j unless the power supply is expected to be used in a remote programming application.

i.) Reconnect jumper A8-A9 and remove remote programming connections.

j.) Check the output voltage with the VOLTAGE control fully clockwise. The DVM should read greater than +20V. If not, readjust A2R58 for a DVM reading of +20.5V.

CHANGE 15:

In the parts list and on the schematic, change for the A2 board, change R3 from 714 ohms 1%, 1/4W, to (p/n 0811-1935) to 400 ohms (p/n 0811-1930) - qty of 1.

CHANGE 16:

In the parts list and on the schematic, change VR1-4 from 6.2V 5% p/n 1902-0777, to 6.2V 2% p/n 1902-0509 (qty 4).

CHANGE 17:

In Table 1-1, under DC Output Isolation, change float voltage to read from "+/- 300 Vdc to ground" to "+/- 120 Vdc to ground".

CHANGE 18:

In the parts list and on the schematic for the A2 board, change R3 from 400 ohms (see Change 15), to 200 ohms 1%, 1/8W, p/n 0757-0407. Also change VR1 - VR4 from 6.2V 2% (see Change 16), to 6.2V 5%, p/n 1902-0777 (qty 4).

CHANGE 19:

In the parts list on page 6-5, change CR12-15 to p/n 1901-1130. If any one of these diodes need replacement, replace all four diodes with the new part number.

CHANGE 20:

In the parts list on page 6-5, change C8,16 to capacitor-assembly, 220uF 250V, p/n 5063-2335 (qty 2).

CHANGE 21:

On page 6-10, change DS2 to p/n 1990-0517.

CHANGE 22:

To comply with CE92 standards, the following information is provided for Table 1-1 to be classified as Supplementary Characteristics: "When subjected to radiated field strengths of 3 volts/meter in the vicinity of 36 MHz to 60 MHz, the full-scale programming accuracy may increase as much as 0.2%. When subjected to radiated field strengths of 3 volts/meter in the vicinity of 100 MHz to 218 MHz, the full-scale programming accuracy may increase as much as 0.8%."

Add the following CAUTION to page 3-1:
CAUTION: "This unit can be damaged by electrostatic discharge into the Output connectors or any other connectors located on the front or rear of the instrument while the unit is turned on. Do not cause an electrostatic discharge into these connectors as may occur when they are touched, while the unit is turned on."

CHANGE 23:

On page 6-10, change Q8,9 to p/n 1853-0462.

CHANGE 24:

On page 6-10, change S1 to p/n 3101-3376. Add Cable (S1), p/n 5063-3483.

6825A TEST RECORD
ATTACHMENT A-1

SERIAL NUMBER _____

TECHNICIAN _____

RUN _____

DATE _____

Final Test:	Spec:	In	Out	Repair
Max I	2.048A +/- .5mA			
CV Load Reg Range:	X1 <0.01% + .5mV = 700uV X4 <0.01% + 1mV = 3mV			
CV Line Reg Range:	X1 <0.01% + .5mV = 7mV X4 <0.01% + 2mV = 4mV			
CV Ripple & Noise Range:	X1 <3mVRMS/8mVP-P X4 <10mVRMS/30mVP-P			
Transient	<100uS to within 20mV			
CC Load Reg.	<.01% + 250uA = 450uA			
CC Line Reg.	<.01% + 250uA = 450uA			
CC Ripple & Noise	< mARMS/15mAP-P Both Ranges			
Amplifier	Freq. THD			
Total Harmonic Distortion	100HZ .08%			
	1KHZ .1%			
	10KHZ .35%			
	20KHZ 1.5%			
	30KHZ 2.2%			
	40KHZ 5%			
Freq. Response:	Fixed Gain: BW=40KHZ @ 27VP-P= Undistorted Sine Wave			
Unit at 40VP-P @ 100HZ	Variable Gain: BW=15KHZ @ 27VP-P= Undistorted Sine Wave			

SECTION I GENERAL INFORMATION

1-1 DESCRIPTION

1-2 This instruction manual contains operating and service instructions for Bipolar Power Supply/Amplifier Model 6825A. The Bipolar Power Supply/Amplifier (BPS/A) is a general purpose instrument useful in any laboratory engaged in the research and development of electronic systems, circuitry, or components. The BPS/A can be operated as a power supply or as an amplifier. Terminals on the rear terminal strip permit access to various internal control points to further expand the operational capabilities of the unit. The resulting flexibility lends the BPS/A to an almost unlimited number of applications. Some of these applications are outlined in Section III of this manual. The following paragraphs describe some of the features of the BPS/A as a power supply and as an amplifier.

1-3 POWER SUPPLY FEATURES

1-4 The unit can be made to function as a regulated dc power supply by setting the front panel MODE switch to the POWER SUPPLY position. The supply can furnish either a Constant Voltage output or Constant Current output. The dc output is bipolar and is continuously adjustable from its maximum rated positive value to an equal negative continuously through zero. A crossover feature automatically changes the supply from constant voltage to constant current operation at a preset or programmed voltage/current point. The front panel CURRENT MODE indicator lights for constant current operation. Both the supply and the load are protected against overvoltage and overcurrent conditions by internal circuits. Dual output voltage ranges are provided for better resolution. The front panel RANGE switch allows selection of the high (X4) or low (X1) output range.

1-5 The output voltage can be programmed locally using the front panel VOLTAGE control, or remotely, by means of a resistance connected to the appropriate rear terminals. The output current can be programmed locally using the front panel CURRENT control, or remotely, by means of a resistance or voltage source connected to the appropriate rear terminals. The BPS/A can be programmed

(controlled) at a very high rate of speed (less than 50 μ sec for output voltage change over the entire voltage span). Local and remote programming connections are described in Section III. The output voltage and current ranges are as follows:

- 5V to +5V at 0 to 2.0A (low range)
- 20V to +20V at 0 to 2.0A (high range)

1-6 The BPS/A can sink, as well as source current, permitting it to serve as a variable load device. The BPS/A can sink up to 50% of the rated output current.

1-7 AMPLIFIER FEATURES

1-8 The unit can be made to function as a variable gain or a fixed gain amplifier by setting the MODE switch to the VAR GAIN AMP or FXD GAIN AMP position. When operating as an amplifier, the BPS/A can amplify externally applied ac or dc signals. Variable gain can be controlled locally (VOLTAGE control) or remotely and is accurate to 0.1%. The variable or fixed gain provided is as follows:

- Variable Gain - 0-2 (low range), 0-8 (high range)
- Fixed Gain - 1X (low range), 4X (high range)

1-9 The variable gain amplifier is non-inverting and has a frequency response from dc to 15kHz. The fixed gain amplifier is inverting and has a frequency response from dc to 40kHz. Total harmonic distortion is 0.1% (maximum).

1-10 METERS

1-11 A voltmeter and an ammeter on the front panel monitor the ac or dc output voltage and current respectively. Associated front panel VOLTAGE METER and CURRENT METER switches allow the meters to monitor either an ac or dc output and also provide dual range monitoring capability for better resolution. The dc meter accuracy is $\pm 3\%$ of full scale and the ac meter accuracy is $\pm 5\%$ of full scale.

1-12 SPECIFICATIONS

1-13 Detailed specifications for this model are given in Table 1-1.

Table 1-1. Specifications, Model 6825A

GENERAL SPECIFICATIONS	
<p>Input Power: 104-127/208-254Vac (switchable), 48-63Hz, 1.0A, 150W</p> <p>Meters: Individual voltage and current meters. DC accuracy is 3% of full scale. AC accuracy is 5% of full scale with sinusoidal, 100Hz input.</p> <p>Meter Ranges (DC): ±2.4V, ±24V/±0.24A, ±2.4A</p> <p>Meter Ranges (AC): 1.6V (uncal), 16V rms/0.16A rms, 1.6A rms</p> <p>Temperature Ratings: Operating: 0 to 55°C. Storage: -40 to +75°C.</p> <p>Cooling: Convection cooling is employed. The supplies have no moving parts.</p> <p>Dimensions: See outline diagram, Figure 2-1.</p> <p>Weight: 18 lbs. (8.2 kg.) net, 21 lbs. (9.5 kg.) shipping.</p>	<p>Source Effect (Line Regulation) Continued: Voltage (X1 Range): .01% + .2mV Voltage (X4 Range): .01% + 2mV Current: .01% + 250μA</p> <p>PARD (Ripple and Noise): Rms/p-p (20Hz to 20MHz) at any line voltage and under any load condition within rating. Voltage (X1 Range): 1.5mV rms/4mV p-p Voltage (X4 Range): 5mV rms/15mV p-p Current: 3mA rms/10mA p-p</p> <p>Temperature Coefficient: Output change per degree Centigrade change in ambient following 30 minutes warm-up. Voltage (X1 Range): .01% + .35mV Voltage (X4 Range): .01% + 1.5mV Current: .02% + 100μA</p> <p>Drift (Stability): Change in output (dc to 20Hz) over 8 hour interval under constant line, load, and ambient following 30 minutes warm-up. Voltage (X1 Range): .03% + 1mV (Pot wiper jump effect may add 5mV) Voltage (X4 Range): .03% + 5mV (Pot wiper jump effect may add 50mV) Current: .1% + 200μA (Pot wiper jump effect may add 1.5mA)</p>
POWER SUPPLY SPECIFICATIONS	
<p>DC Output: Voltage and current spans indicate range over which output may be varied. X1 Range: -5V to +5V, 0 to 2.0A X4 Range: -20V to +20V, 0 to 2.0A</p> <p>Load Effect (Load Regulation): Voltage load effect is given for a load current change equal to the current rating of the supply. Current load effect is given for a load voltage change equal to the voltage rating of the supply. Voltage (X1 Range): 0.01% + .1mV Voltage (X4 Range): 0.01% + .5mV Current: .01% + 250μA</p> <p>Source Effect (Line Regulation): For a change in line voltage between 104 and 127Vac/208 and 254Vac at any output voltage and current within rating.</p>	<p>Load Effect Transient Recovery (Load Transient Recovery): Time required for output voltage recovery to within the specified level of the nominal output voltage following a change in output current equal to the current rating of the supply: 100μsec is required for output voltage recovery within 20mV of nominal output voltage.</p> <p>Resolution: Typical output voltage or current change that can be obtained using front panel controls. Voltage (X1 Range): 10mV Voltage (X4 Range): 40mV Current: 3mA</p> <p>Output Impedance (Typical to 50kHz): Approximated by a resistance in series with an inductance (constant voltage operation). .5mΩ & 1.5μH</p>

Table 1-1. Specifications, Model 6825A (Continued)

POWER SUPPLY SPECIFICATIONS (Continued)	
<p>DC Output Isolation: Supply may be floated at up to 300V above ground.</p> <p>Remote Resistance Programming: Resistance Coefficient: Voltage (X1 Range): 2000Ω/V ± .1% Voltage (X4 Range): 500Ω/V ± .1% Current: 5Ω/mA ± .1%</p> <p>Remote Programming Speed: 50μsec are required to change between 1% and 99% of the maximum + and - voltage limits.</p> <p>Remote Programming Temperature Coefficient: Output change per degree Centigrade change in ambient using an external control resistor (R_F) at output voltage (V_O) or current (I_O). % T.C. R_F is the temperature coefficient of the control resistance R_F. Voltage (X1 Range): .25mV + .007% (V_O) + % T.C. R_F (V_O + 5) Voltage (X4 Range): 1mV + .007% (V_O) + % T.C. R_F (V_O + 20) Current: .016% (I_O) + 33μA + % T.C. R_F (I_O)</p> <p>Sink Current Compliance: Maximum current that the supply can sink when connected to an active load.</p> <div style="text-align: center;"> </div> <p>Sink current is limited to a value ranging linearly from 2A @ 0V to 1A @ 20V. Externally applied voltages to output terminals in excess of 25V could damage the instrument.</p>	<p>Voltage Gain (High/Low Range): Fixed Amplifier (Inverting): 4X (high range)/1X (low range) Variable Gain (Non-Inverting): 0-8 (high range)/0-2 (low range)</p> <p>Frequency Response (+1, -3dB at full output): Fixed Gain: dc - 40kHz Variable Gain: dc - 15kHz</p> <p>Distortion: Total harmonic distortion is .1% (maximum) at 100Hz and full output.</p> <p>Input Impedance: 10KΩ (Typical)</p> <p>Fixed Gain Accuracy (at 100Hz): Low Range (X1): .1% + .5mV High Range (X4): .1% + 2mV</p> <p>Remote Resistance Programming Variable Gain (A_V): $A_V = \frac{K R_F}{10.24 \times 10^3 \Omega}$, where K is the constant indicated and R_F is the external control resistance. $A_V \text{ at low range (X1): } \frac{R_F}{10.24 \times 10^3}$ $A_V \text{ at high range (X4): } \frac{4 R_F}{10.24 \times 10^3}$</p> <p>Variable Gain Accuracy: Accuracy in high range at 100Hz using an external control resistance (R_F) at output voltage (V_O). % R_F is the accuracy of the control resistance R_F. (.05% + %R_F) V_O + 2.5mV</p> <p>Remote Voltage Control Coefficient: Fixed gain amplifier mode, voltage coefficient: Voltage (X1 Range): 1 volt/volt ± .1% Voltage (X4 Range): 4 volts/volt ± .1%</p> <p>Variable gain amplifier mode (VOLTAGE control fully clockwise), voltage coefficient: Voltage (X1 Range): 2 volts/volt ± .1% Voltage (X4 Range): 8 volts/volt ± .1%</p> <p>Constant Current, voltage coefficient (the following applies to variable gain amplifier, fixed gain amplifier, and power supply modes of operation): 2 amperes/volt ± .5%</p>
POWER AMPLIFIER SPECIFICATIONS	
<p>Output: Voltage (X1 Range): 10V p-p Voltage (X4 Range): 40V p-p Current: 2A peak</p>	

1-14 OPTIONS

1-15 Options are customer-requested factory modifications of a standard instrument. The option described below applies to Model 6825A.

<u>Option No.</u>	<u>Description</u>
007	<u>Ten-turn Output Voltage Control:</u> Replaces standard single-turn voltage control to allow greater resolution in setting the output voltage of supply.

1-16 ACCESSORIES

1-17 The accessories listed in the following chart may be ordered with the instrument or separately from your local Hewlett-Packard sales office (refer to list at rear of manual for addresses).

<u>HP Part No.</u>	<u>Description</u>
5060-8762	Dual Rack Adapter: Kit for rack mounting one or two supplies in standard 19-inch rack.
5060-8760	Blank Panel: Filler panel to block unused half of rack when mounting only one supply.
11057A	Carrying handle easily attached for portability and handling convenience.
1052A	Combining Case for mounting one or two units in standard 19-inch rack.
5060-0789	Cooling kit for above combining case, 115 Vac, 50-60Hz.
5060-0796	Cooling kit for above combining case, 230 Vac, 50-60Hz.

1-18 INSTRUMENT IDENTIFICATION

1-19 Hewlett-Packard power supplies are identified by a three-part serial number. The first part is the power supply model number. The second part is the serial number prefix, consisting of a number-letter combination denoting the date of a significant design change and the country of manufacture. The first two digits indicate the year (12 = 1972, 13 = 1973, 20 = 1980, etc.); the second two digits indicate the week (01 through 52); and the letter "A", "G", "J", or "U" designates the U.S.A., West Germany, Japan, or the United Kingdom, respectively, as the country of manufacture. The third part is the power supply serial number; a different 5-digit sequential number is assigned to each power supply, starting with 00101.

1-20 If the serial number prefix on your unit does not agree with the prefix on the title page of this manual, change sheets supplied with the manual or manual backdating changes in Appendix A define the differences between your instrument and the instrument described by this manual.

1-21 ORDERING ADDITIONAL MANUALS

1-22 One manual is shipped with each instrument. Additional manuals may be purchased from your local Hewlett-Packard field office (see list at rear of this manual for addresses). Specify the model number, serial number prefix, and HP part number shown on the title page.

SECTION II INSTALLATION

2-1 INITIAL INSPECTION

2-2 Before shipment, this instrument was inspected and found to be free of mechanical and electrical defects. As soon as the instrument is received, proceed as instructed in the following paragraphs.

2-3 MECHANICAL CHECK

2-4 If external damage to the shipping carton is evident, ask the carrier's agent to be present when the instrument is unpacked. Check the instrument for external damage such as broken controls or connectors, and dents or scratches on the panel surfaces. If the instrument is damaged, file a claim with the carrier's agent and notify your local Hewlett-Packard Sales and Service Office as soon as possible (see list at rear of this manual for addresses).

2-5 ELECTRICAL CHECK

2-6 Check the electrical performance of the instrument as soon as possible after receipt. Section V of this manual contains performance check procedures which will verify instrument operation within the specifications stated in Table 1-1. This check is also suitable for incoming quality control inspection. Refer to the inside front cover of the manual for the Certification and Warranty statements.

2-7 REPACKAGING FOR SHIPMENT

2-8 To insure safe shipment of the instrument, it is recommended that the package designed for the instrument be used. The original packaging material is reusable. If it is not available, contact your local Hewlett-Packard field office to obtain the materials. This office will also furnish the address of the nearest service office to which the instrument can be shipped. Be sure to attach a tag to the instrument specifying the owner, model number, full serial number, and service required, or a brief description of the trouble.

2-9 INSTALLATION DATA

2-10 The instrument is shipped ready for bench operation. It is necessary only to connect the instrument to a source of power and it is ready for operation.

2-11 LOCATION

2-12 This instrument is convection cooled. Sufficient space should be allotted so that a free flow of cooling air can reach the top and rear of the instrument when it is in operation. It should be used in an area where the ambient temperature remains between 0°C and +55°C.

2-13 OUTLINE DIAGRAM

2-14 Figure 2-1 illustrates the outline shape and dimensions of the BPS/A.

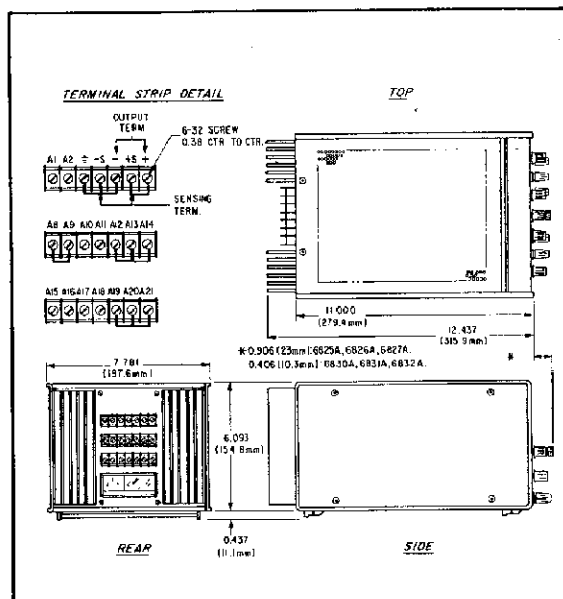

Figure 2-1. Outline Diagram

2-15 RACK MOUNTING

2-16 The BPS/A may be rack mounted using either the dual rack adapter kit or the combining case (with appropriate cooling kit) described in Paragraph 1-16. The necessary installation instructions are provided with the accessories. Refer to Paragraph 5-91 before proceeding with the rack mounting installation instructions.

2-17 INPUT POWER REQUIREMENTS

2-18 The BPS/A may be operated continuously from either a nominal 120 volt or 240 volt, 48-63Hz power source. A two-position selector switch (↓) located within the ac power module on the rear panel selects the power source. Before connecting the instrument to the power source, check that the selector switch setting matches the nominal line voltage of the source. If required, move the switch to the other position. Note that the power cable must be removed, the plastic door on the power module must be moved aside, the fuse extractor must be pulled outward and the fuse must be removed in order to gain access to the selector switch.

2-19 When the instrument leaves the factory, the proper fuse is installed for 115 volt operation. An envelope containing a fuse for 230 volt operation is attached to the instrument. Make sure that the correct fuse is installed if the

position of the slide switch is changed (2A for 115 volt operation, and 1A for 230 volt operation).

2-20 POWER CABLE

2-21 To protect operating personnel, the National Electrical Manufacturers' Association (NEMA) recommends that the instrument panel and cabinet be grounded. This instrument is equipped with a three conductor power cable. The third conductor is the ground conductor and when the cable is plugged into an appropriate receptacle, the instrument is grounded. The offset pin on the power cable's three-prong connector is the ground connection.

2-22 To preserve the protection feature when operating the instrument from a two-contact outlet, use a three-prong to two-prong adapter and connect the green lead on the adapter to ground.

SECTION III OPERATING INSTRUCTIONS

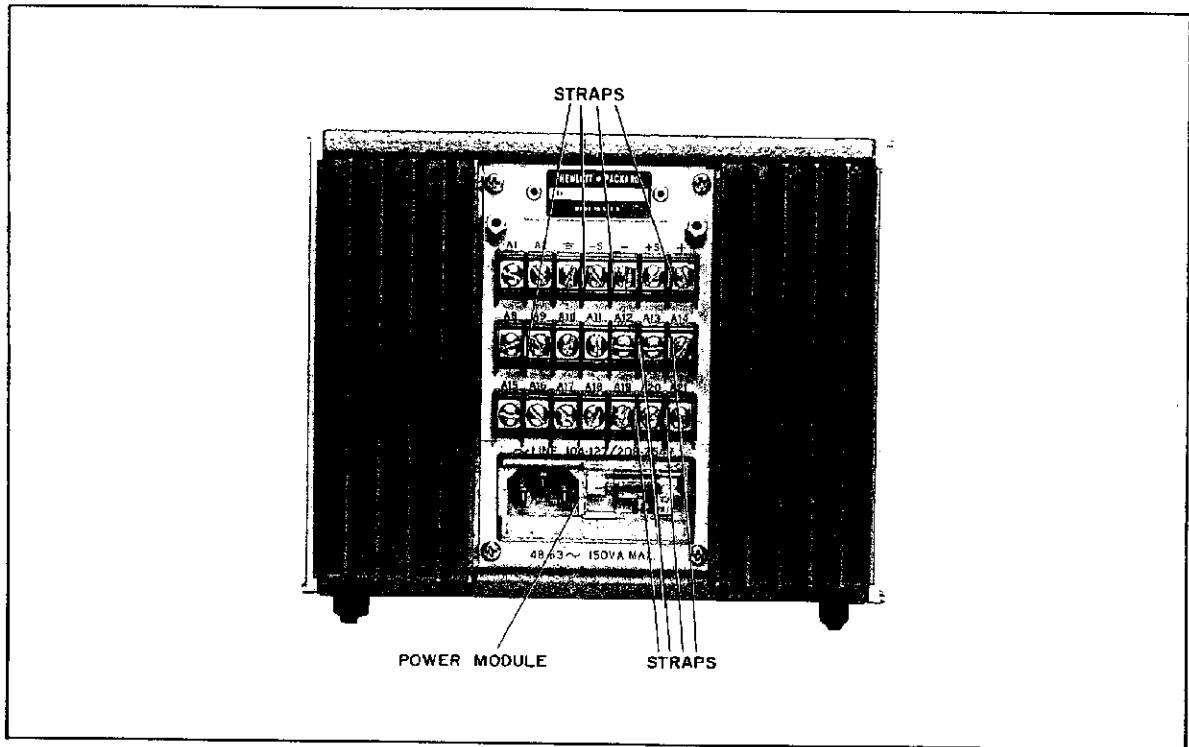

Figure 3-1. Bipolar Power Supply/Amplifier, Rear View

3-1 INTRODUCTION

3-2 This section describes the operating controls and indicators, the turn-on checkout sequence, and operating modes of the Bipolar Power Supply/Amplifier (BPS/A). Local and remote programming operations are also described.

3-3 REAR TERMINALS AND AC INPUT

3-4 The Bipolar Power Supply/Amplifier (BPS/A) is shipped with the rear terminals strapped for local programming (using front panel controls) as shown in Figure 3-1. Remote programming strapping requirements are described in subsequent paragraphs. The power module contains fuse F1 (2A for 115Vac or 1A for 230Vac) and a slide switch for connecting 115Vac or 230Vac input power to the instrument. To turn on the BPS/A, set the LINE switch (item ①, Figure 3-2) to ON. The LINE ON indicator ②

should light. Fuse F1 protects the main power supply. At initial turn-on, an internal circuit protects any loads connected to the BPS/A from turn-on transients by shorting the output terminals and disabling the BPS/A's power output circuits. This circuit operates similarly at turn-off to protect any loads from turn-off transients.

3-5 OPERATING CONTROLS AND INDICATORS

3-6 MODE SWITCH

3-7 The MODE switch ③ allows the BPS/A to operate as a power supply, variable gain amplifier, or a fixed gain amplifier. In power supply operation, the BPS/A provides a variable bipolar dc output voltage dependent upon the RANGE switch ④ and VOLTAGE control ⑤ settings. The dc output voltage ranges are as follows:
-5V to +5V (low range) and -20V to +20V (high range).

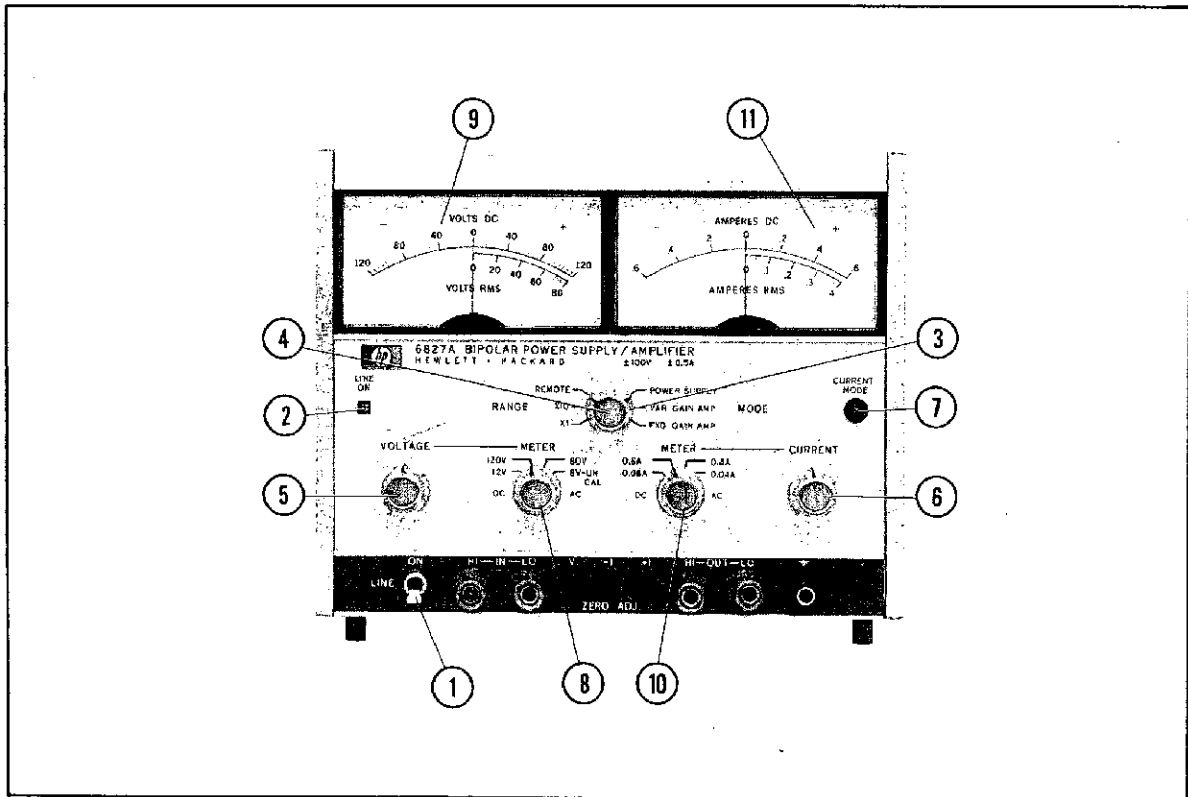

Figure 3-2. Operating Controls and Indicators (Typical BPS/A)

3-8 In variable gain amplifier operation, the BPS/A can amplify or attenuate an external input signal (dc to 15kHz) applied to the HI and LO IN terminals. The gain is variable from 0 to a maximum depending upon the RANGE switch (4) and VOLTAGE control (5) settings. The variable gain ranges are as follows: 0-2 (low range) and 0-8 (high range).

3-9 In fixed gain amplifier operation, the BPS/A inverts and amplifies an external input signal applied to the HI and LO IN terminals. For fixed gain amplifier operation, the BPS/A has a frequency response from DC to 40kHz. The fixed voltage gain provided in the high or low output range is as follows: times 1 (low range) and times 4 (high range).

3-10 RANGE SWITCH

3-11 The RANGE switch (4) allows selection of the high (X4) or low (X1) output ranges for power supply, variable gain amplifier, or fixed gain amplifier operation. The REMOTE position allows the high or low range to be externally selected via the rear terminal strip (see Paragraph 3-45).

3-12 VOLTAGE CONTROL

3-13 The VOLTAGE control (5) controls the output level (power supply operation) or gain (variable gain amplifier operation) of the BPS/A. In power supply operation, the VOLTAGE control varies the output voltage from a maximum negative value (full counterclockwise) through zero (midposition) to a maximum positive value (full clockwise). In variable gain amplifier operation, the gain is variable from zero to the maximum gain as the VOLTAGE control is varied from full counterclockwise to full clockwise. In fixed gain amplifier operation, the VOLTAGE control does not control circuit operation.

3-14 CURRENT CONTROL

3-15 The CURRENT control (6) sets the constant current output of the BPS/A. This control is operable in all three modes of operation (power supply, variable gain amplifier, and fixed gain amplifier) and controls the output current from 0 to the maximum rated output. When the instrument switches from constant voltage to constant current operation, the CURRENT MODE indicator (7) lights.

Selection of constant voltage or constant current operation is described in Paragraphs 3-27 and 3-28.

3-16 VOLTAGE METERING

3-17 The VOLTAGE METER switch (8) permits monitoring the DC or AC output voltage on voltmeter (9). The shaded area on the voltmeter face indicates the amount of output voltage that is available in excess of the normal rated output. The voltmeter upper scale reads the bipolar DC voltage from a maximum negative value through 0V to a maximum positive value, DC accuracy is $\pm 3\%$ of full scale. The lower scale reads the RMS output voltage from 0 to a maximum level. AC accuracy is $\pm 5\%$ of full scale. The voltmeter ranges selected by the VOLTAGE METER switch are as follows:

DC	AC(RMS)
0 to $\pm 2.4V$,	0 to 1.6V (uncal),
0 to $\pm 24V$	0 to 16V

3-18 CURRENT METERING

3-19 The CURRENT METER switch (10) permits monitoring the DC or AC output current on ammeter (11). The shaded area on the ammeter face indicates the amount of output current that is available in excess of the normal rated output. The ammeter upper scale reads the bipolar DC current from a maximum negative value through 0A to a maximum positive value. DC accuracy is $\pm 3\%$ of full scale. The lower scale reads the RMS output current from 0 to a maximum level. AC accuracy is $\pm 5\%$ of full scale. The ammeter ranges selected by the CURRENT METER switch are as follows:

DC	AC(RMS)
0 to $\pm 0.24A$,	0 to 0.16A,
0 to $\pm 2.4A$	0 to 1.6A

3-20 TURN-ON CHECKOUT PROCEDURES

CAUTION

Rear terminal strip cover must be in place when instrument is in use.

3-21 The following turn-on and checkout procedures are performed utilizing the front panel controls (Figure 3-2) and the normal rear terminal strapping connections as received from the factory. Also, the Local/Auto switch, located inside the instrument on board A2, is in the Local position (pushed to the right or toward the rear of the instrument) as received from the factory. The AUTO position is used for auto-series and auto-parallel operations (see

Paragraphs 3-57 through 3-61). The following procedures check both power supply and amplifier to ensure that the BPS/A is operational.

POWER SUPPLY CHECKOUT PROCEDURE

- a. Set front panel controls as follows:
 - MODE switch (3) – POWER SUPPLY
 - RANGE switch (4) – X1
 - VOLTAGE control (5) – midposition
 - CURRENT control (6) – full clockwise
 - VOLTAGE METER switch (8) – low range DC
 - CURRENT METER switch (10) – high range DC
- b. Set LINE switch (1) to ON and observe that LINE ON indicator (2) lights.
- c. Adjust VOLTAGE control (5) from full counterclockwise (–) to full clockwise (+) range through 0V and note that maximum output is attained as indicated on meter (9).
- d. Set VOLTAGE-METER switch (8) to high range DC and RANGE switch (4) to X4 position.
- e. Adjust VOLTAGE control (5) clockwise and counterclockwise through entire bipolar output voltage range through 0 and note that maximum output is attained as indicated on meter (9). Adjust output voltage to +20V.
- f. To checkout the constant current circuit, first turn off BPS/A. Short circuit the front panel terminals (HI OUT to LO OUT).
- g. Turn on supply and observe that CURRENT MODE indicator (7) lights and meter (9) indicates near 0 volts.
- h. Adjust CURRENT control (6) from full cw to full ccw and note that minimum current is attained as indicated on meter (11).
- i. Turn off supply and remove short from output terminals.
- j. Turn on supply and adjust VOLTAGE CONTROL (5) for an output of –20V.
- k. Turn off supply and reconnect short across the HI and LO OUT terminals.
 - l. Turn on supply and note that CURRENT MODE indicator (7) lights and meter (9) indicates 0 volts.
 - m. Adjust CURRENT control (6) from full cw to full ccw and note that minimum current is attained as indicated on meter (11).
 - n. Turn off BPS/A and remove short from output terminals.

VARIABLE GAIN AMPLIFIER CHECKOUT PROCEDURE

- a. Set front panel controls as follows:
 - MODE switch (3) – VAR GAIN AMP
 - RANGE switch (4) – X1
 - VOLTAGE control (5) – midposition
 - CURRENT control (6) – full clockwise
 - VOLTAGE METER switch (8) – low range AC
 - CURRENT METER switch (10) – high range AC
- p. Connect a 1.75V rms, 100Hz input signal to the

front panel input terminals (HI and LO IN).

q. Turn on supply and adjust VOLTAGE control (5) through entire RMS range and note that maximum voltage is attained as indicated on meter (9)

r. Set VOLTAGE METER switch (8) to high range AC, RANGE switch (4) to X4, and adjust VOLTAGE control (5) through entire RMS range and note that maximum voltage is attained as indicated on meter (9)

FIXED GAIN AMPLIFIER CHECKOUT PROCEDURES

s. Set MODE switch (3) to FXD GAIN AMP position and increase input signal to 3.5V rms.

t. Adjust VOLTAGE control (5) through entire RMS range and note that maximum voltage is attained as indicated on meter (9)

3-22 OPERATING MODES

CAUTION

Rear terminal strip cover must be in place when instrument is in use.

3-23 The position of the front panel MODE switch determines whether the instrument will be used as a power supply or an amplifier. In addition, the instrument may be controlled locally using the front panel VOLTAGE and CURRENT controls or remotely via terminals on the rear of the unit. The front panel output terminals (HI and LO OUT) and input terminals (HI and LO IN) are repeated as (+ and -) and (A1 and A2) respectively on the rear terminal strip. The rear terminal strip includes sensing (+S and -S) terminals and other terminals for remote control of the BPS/A as shown in Figure 3-3. These terminals connect to various control points within the instrument and allow

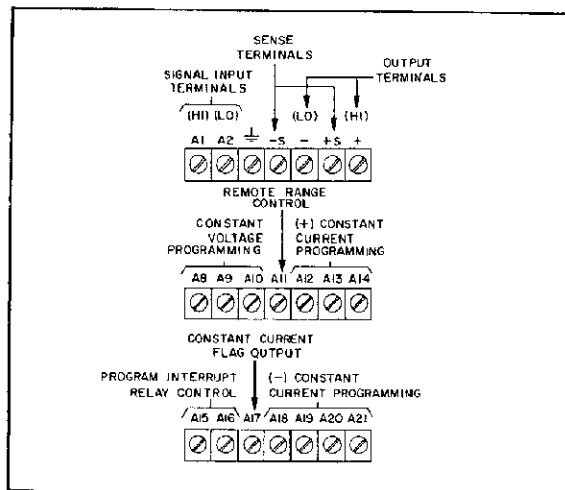

Figure 3-3. Rear Terminal Strip

strapping connections to be made which enable the power supply or amplifier to be utilized in many applications. The following paragraphs describe the procedures for utilizing the various operational capabilities of the power supply. A more theoretical description concerning the operational features of this supply is contained in Application Note 90 and in various Tech. Letters. Copies of these can be obtained from your local Hewlett-Packard field office.

3-24 LOCAL PROGRAMMING

3-25 The BPS/A is shipped with its rear terminal strapping connections arranged for constant voltage/constant current, local programming, local sensing, single unit mode of operation. This strapping pattern is illustrated in Figure 3-4. Also, the Local/Auto switch on board A2 (see Paragraph 3-54) is in the Local position when the instrument is shipped from the factory. This switch must be in the Local position for single unit mode of operation.

3-26 The operator selects either power supply, variable gain amplifier, or fixed gain amplifier operation (MODE switch) and also selects either constant voltage or a constant current output using the front panel VOLTAGE and CURRENT controls (for local programming, no strapping changes are required). Constant voltage or constant current operation are selected as described in the following paragraphs.

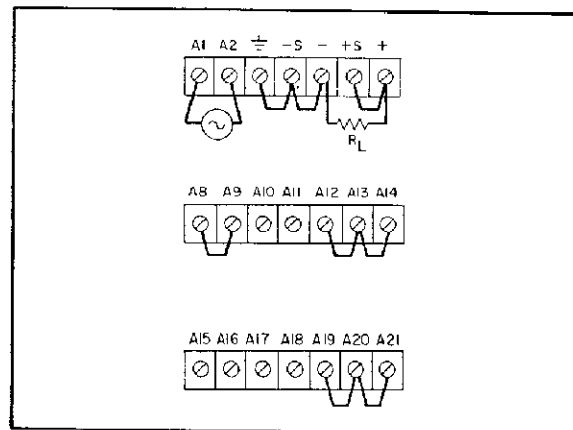

Figure 3-4. Normal Strapping Pattern (LOCAL Programming)

3-27 **Constant Voltage.** To select a constant voltage output, proceed as follows:

- Remove load from output terminals; turn-on supply and adjust VOLTAGE control for desired output voltage.
- Short output terminals and adjust CURRENT control for maximum output current allowable (current limit) as determined by load conditions and voltage range selected

in step (a). If a load change takes place and causes the output current to exceed this setting, the power supply will automatically crossover to constant current mode and output current will be constant at the level set by the CURRENT control. The CURRENT MODE indicator will come on and output voltage will drop proportionately to maintain constant current.

3-28 Constant Current. To select a constant current output, proceed as follows:

- a. Short output terminals and adjust CURRENT control for desired output current.
- b. Open output terminals and adjust VOLTAGE control for maximum output voltage allowable as determined by load conditions and current selected in step (a). If a load change causes the voltage to rise, the power supply will automatically crossover to constant voltage at the voltage setting and output current will drop proportionately.

3-29 OPERATION OF SUPPLY BEYOND RATED OUTPUT

3-30 The shaded area on the front panel meters indicate the amount of output voltage and current that is available in excess of normal rated output. Although, the BPS/A can be operated in this region without damage, it cannot be guaranteed to meet all of its performance specifications.

3-31 REACTIVE LOAD CONSIDERATIONS

3-32 The life and performance of the instrument can be preserved if the following simple precaution is observed when driving reactive loads. Always set/program the VOLTAGE control for zero output before removing a capacitive load or interrupting an inductive load.

3-33 CONNECTING LOAD

3-34 Each load should be connected to the power supply output terminals (front or rear) using separate pairs of connecting wires. This will minimize mutual coupling effects between loads and will retain full advantage of the low output impedance of the power supply. Each pair of connecting wires should be as short as possible and twisted or shielded to reduce noise pickup. (If a shielded pair is used, connect the shield to ground at the power supply and leave the other end unconnected.)

3-35 If load considerations require that the output power distribution terminals be remotely located from the power supply, then the power supply output terminals should be connected to the remote distribution terminals via a pair of twisted or shielded wires and each load should be separately connected to the remote distribution terminals. For this

case, remote sensing should be used. (Refer to Paragraph 3-39).

3-36 Always use two leads to connect the load to the supply, regardless of where the setup is grounded. This will eliminate any possibility of output current return paths through the power source ground. The supply can also be operated up to 300Vdc above ground if neither output terminal is grounded.

3-37 REMOTE SENSING

3-38 Remote sensing is used to maintain good regulation at the load and reduce the degradation of regulation which would occur due to the voltage drop in the leads between the power supply and the load. Remote sensing is accomplished by utilizing the strapping pattern shown in Figure 3-5. The power supply should be turned off before changing strapping patterns. The leads from the sensing ($\pm S$) terminals to the load will carry much less current than the load leads and it is not required that these leads be as heavy as the load leads. However, they must be twisted or shielded to minimize noise pickup.

CAUTION

Observe polarity when connecting sense leads to the load.

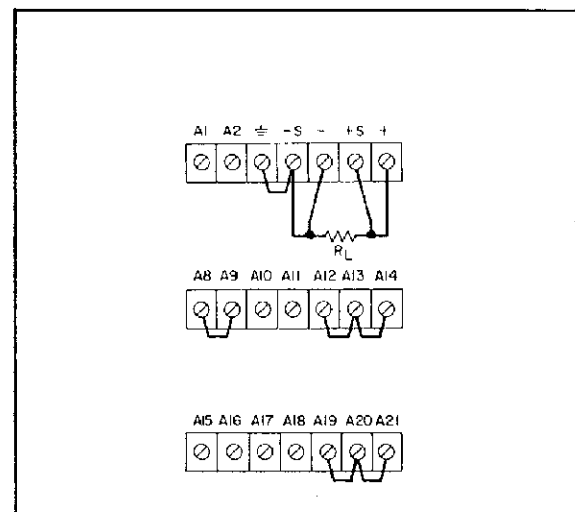

Figure 3-5. Remote Load Sensing

3-39 For reasonable load lead lengths, remote sensing limits degradation of the performance of the supply. However, if the load is located a considerable distance from the

supply, added precautions must be observed to obtain satisfactory operation. Notice that the voltage drop in the load leads subtracts directly from the available output voltage. Because of this, it is recommended that the drop in each load lead not exceed 1.0 volt. If a larger drop must be tolerated, please consult an HP Sales Engineer.

NOTE

Due to the voltage drop in the load leads, it may be necessary to readjust the constant current crossover limit setting in the remote sensing mode.

3-40 REMOTE PROGRAMMING

CAUTION

A programming device or programming resistors must be connected to the appropriate rear terminals and the rear terminal strip cover must be in place when the instrument is in use. Also, if resistive ladder networks are utilized to program the constant voltage/constant current outputs, ensure that make-before-break switching is employed so that the BPS/A's voltage and current programming terminals are not momentarily opened. If the programming terminals should open, the output voltage/current will rise to a value that might damage the load.

3-41 The constant voltage and constant current outputs of the BPS/A can be programmed (controlled) from a remotely located device such as HP 6940A Multiprogrammer or HP 6941A Multiprogrammer Extenders. Either a resistance or voltage source can be used as the programming device. The wires connecting the programming terminals on the rear of the BPS/A to the remote programming device should be twisted or shielded to reduce noise pickup.

3-42 **Resistance Programming Constant Voltage.** A programming resistor (R_{PV}), connected as shown in Figure 3-6, can be used to control the voltage output or gain provided that the MODE switch is in the POWER SUPPLY or the VARIABLE GAIN AMP position. Resistance programming of the constant voltage output is not applicable in the FXD GAIN AMP mode of operation. The VOLTAGE control on the front panel is disconnected (disabled) for the strapping connections shown in Figure 3-6. To maintain the stability and temperature coefficient of the instrument, use programming resistors that have stable low noise and low temperature characteristics (less than 20 ppm/ $^{\circ}$ C.). Also, they should operate at less than 1/30th of their wattage rating to minimize short term temperature effects.

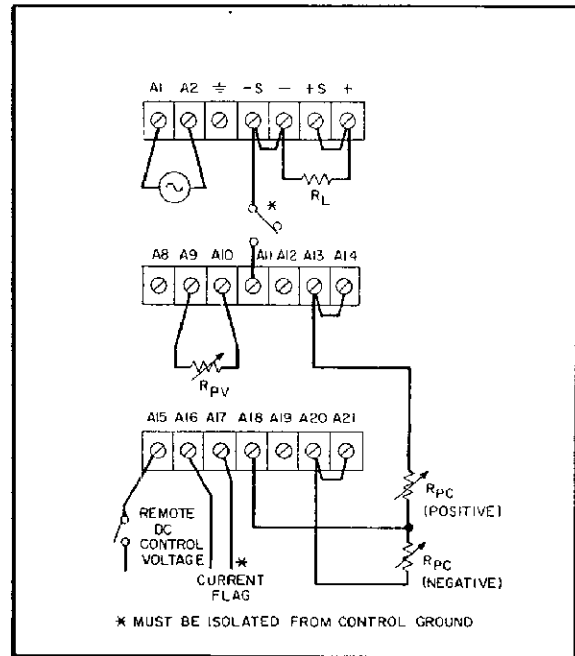

Figure 3-6. Remote Resistance Programming, Constant Voltage/Constant Current

NOTE

Precision programming resistors ($\pm .05\%$) resistors must be used.

3-43 **Power Supply.** For power supply operation, the bipolar output voltage varies linearly from a maximum negative value through zero to a maximum positive value according to the value of the programming resistance R_{PV} . The voltage output ranges and corresponding values of R_{PV} are as follows:

R_{PV} VALUE	6825A	
	HIGH RANGE	LOW RANGE
0	-20.48V	-5.12V
10.24K Ω	0V	0V
20.48K Ω	+20.48V	+5.12V

3-44 As noted above, the output voltage should be zero volts with 10.24K connected to the programming terminals. The output may be adjusted to zero by adjusting the V

ZERO ADJ potentiometer as described in Paragraph 5-104. The output voltage varies from the maximum negative value to the maximum positive value through 0 at a rate determined by the resistance programming coefficient as follows:

- High range (X4): 500ohms/volt \pm .1%
- Low range (X1): 2000ohms/volt \pm .1%

CAUTION

When remote control programming is employed, the FLAG (A17) and REMOTE RANGE (A11) programming connections must be isolated from the computer ground.

3-45 The switch connected between the A11 and -S terminals allows remote selection of the high (X4) or low (X1) range. Note that the front panel RANGE switch must be in the REMOTE position in order to utilize the remote selection feature. The remote dc control voltage connections between terminals A15 and A16 activate an internal relay. When the control voltage is applied, the internal relay is energized momentarily disabling the input driver to the BPS/A error amplifier. This feature is used to prevent transients from affecting the output when the programming input is changed. Terminal A17 provides an indication to the external programming device when the BPS/A is in constant current operation.

3-46 Variable Gain Amplifier. For variable gain amplifier operation, an external input signal (dc to 15kHz), applied to terminals A1 (HI IN) and A2 (LO IN), is amplified or attenuated. The gain is variable from 0 to a maximum value as the value of R_{pV} varies from 0 to 20.48K ohms. The variable gain is from 0 to 8 in the high range and from 0 to 2 in the low range.

CAUTION

The voltage applied to the input terminals, HI IN (A1) and LO IN (A2), must not exceed 50V (maximum) or the instrument may be damaged.

3-47 Resistance Programming, Constant Current. Programming resistors (R_{pC}), connected as shown in Figure 3-6, can be used to control the constant current output. The front panel CURRENT control is disconnected (disabled) when the remote R_{pC} resistors are connected as indicated. Resistance programming of the constant current output can be accomplished in all three modes of operation (power supply, variable gain amplifier, and fixed gain amplifier).

Individual precision (\pm 0.05%) R_{pC} resistors control positive and negative constant current outputs respectively. The positive or negative output current is variable from 0 to 2.048A at a rate determined by the programming coefficient as follows: 5 ohms/mA \pm .1%.

CAUTION

A load must be maintained at all times during constant current operation. The load can be a 40K Ω resistor.

3-48 Zero output current for zero programming resistance can be assured through proper adjustment of the front panel +I and -I ZERO ADJ potentiometers (see Paragraph 5-107).

3-49 Voltage Programming, Constant Voltage. Voltage programming of the output voltage can be accomplished in the variable gain or fixed gain amplifier mode of operation. Voltage programming is not applicable in the power supply mode.

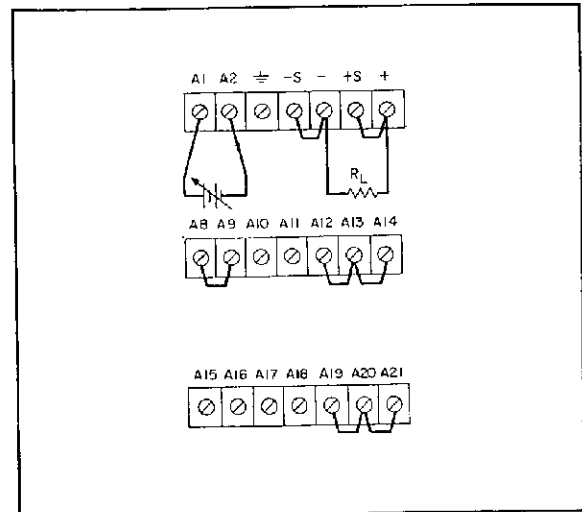

Figure 3-7. Remote Voltage Programming, Constant Voltage

3-50 Variable Gain Amplifier. AC signals or a dc level (positive or negative) can be amplified or attenuated in the variable gain amplifier mode. Figure 3-7 shows a variable dc level (programming voltage) applied to the input terminals A1 (HI IN) and A2 (LO IN). Since the BPS/A is non-inverting in the variable gain amplifier mode, a positive input (A1 positive, A2 negative) results in a positive output and a

negative input (A1 negative, A2 positive) results in a negative output. The other connections on Figure 3-7 are shown for local control using front panel controls, however, remote control using external controls may also be employed. The front panel or remote voltage controls can be used to attenuate or amplify the input as required. With the front panel VOLTAGE control or remote programming resistor set for maximum output, the programming coefficient is as follows:

- High Range (X4): 8 volts/volt \pm .1%
- Low Range (X1): 2 volts/volt \pm .1%

3-51 Fixed Gain Amplifier. AC signals up to 40kHz or a dc level (positive or negative) can be amplified in the fixed gain amplifier mode. Figure 3-7 shows a variable dc level (programming voltage) applied to the HI (A1) and LO (A2) input terminals. Since the BPS/A provides an inverted output in the fixed gain amplifier mode, a positive input (A1 positive, A2 negative) results in a negative output and a negative input (A1 negative, A2 positive) results in a positive output. The front panel or remote programming voltage controls are not applicable in this mode. The programming coefficient in the fixed gain amplifier mode is as follows:

- High Range (X4): 4 volts/volt \pm .1%
- Low Range (X1): 1 volt/volt \pm .1%

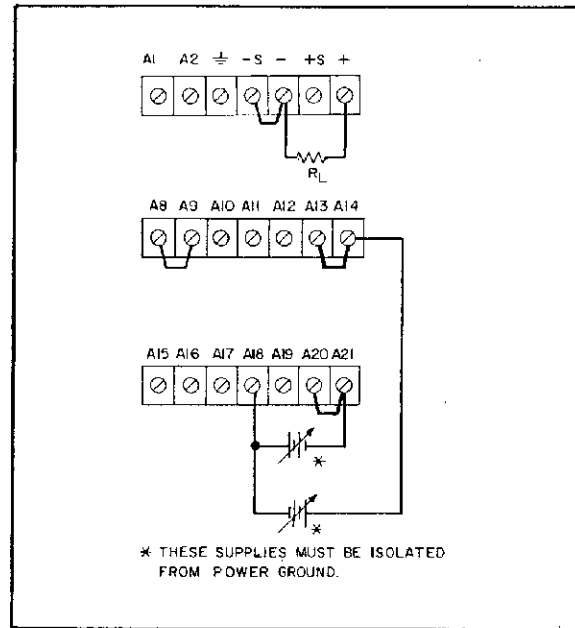

Figure 3-8. Remote Voltage Programming, Constant Current

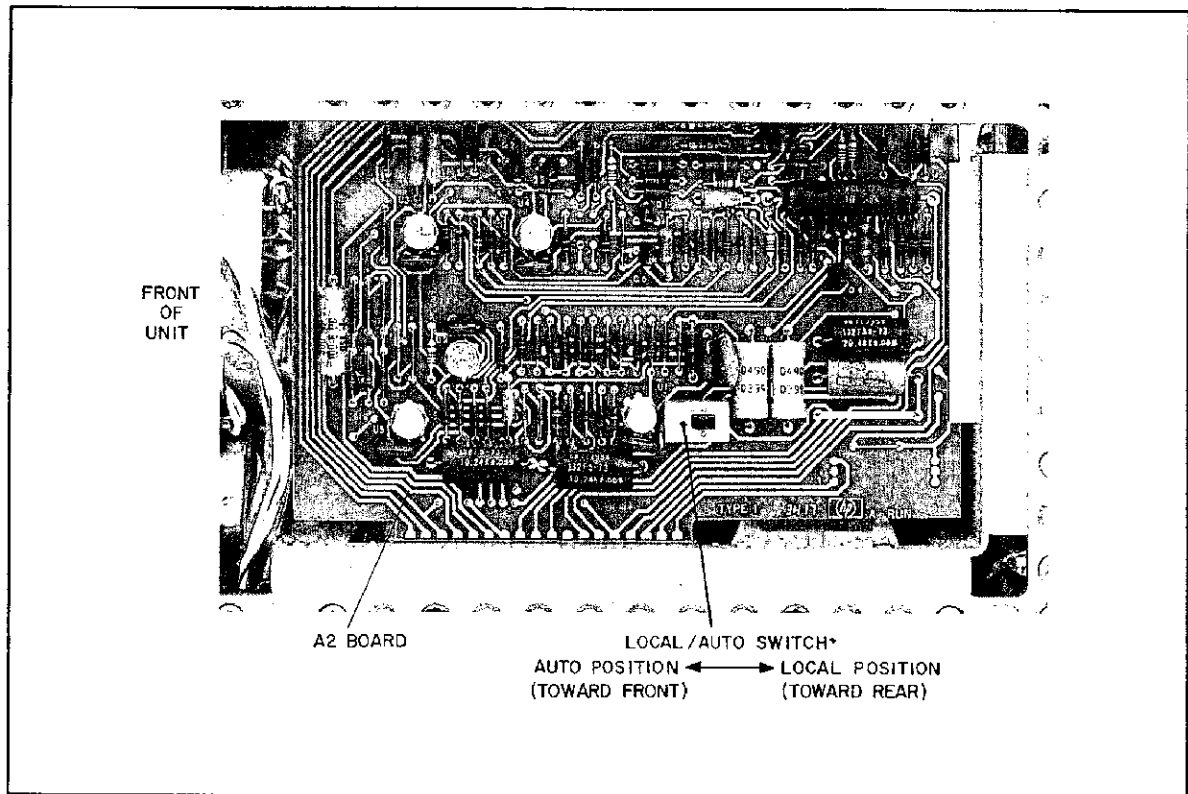

Figure 3-9. Local/Auto Switch

3-52 Voltage Programming, Constant Current. Voltage programming of the output current can be accomplished in all three operating modes (power supply, variable gain amplifier, and fixed gain amplifier). Positive and negative dc programming voltages are connected to terminals A14 and A21 respectively as shown in Figure 3-8. The positive or negative output current will vary linearly with changes in the programming voltages. The output current varies at a rate determined by the programming coefficient. The programming coefficient is 2 amps/1 volt. The maximum rated output current is 2A, therefore, the maximum programming voltage is 1 volt.

3-53 SERIES AND PARALLEL CONNECTIONS

3-54 The following paragraphs describe the connections required for combining BPS/A's for series and parallel operations. These connections are employed whenever it is required to extend the voltage/gain or current capability beyond one supply. For series operation, the total output voltage/gain is the sum of the voltages/gains of the individual supplies. For parallel operation, the total output current is the sum of the output current from the individual supplies. For series or parallel operation, the BPS/A's must be operated in the same mode (power supply, variable gain amplifier, or fixed gain amplifier). Also, each supply must have its Auto/Local switch A2S1 (see Figure 3-9) in the Local position (pushed toward the rear of the instrument). Note that the external signal applied to the A1 and A2 terminals is internally disconnected when the BPS/A's are in the power supply mode.

3-55 Series Connections. Two or more supplies may be connected in series to obtain a higher voltage/gain than is available from a single supply. Figure 3-10 illustrates the series connections for three supplies. Each of the supplies must be adjusted in order to obtain the desired output/voltage gain.

3-56 Parallel Connections. Parallel operation of BPS/A is possible because of the constant voltage/constant current crossover feature. Two or more power supplies can be connected in parallel to obtain a total output current greater than that available from one power supply. The total output current is the sum of the output currents of the individual power supplies. The load must be selected so that the current limit of one supply is exceeded allowing it to operate in the constant current mode. The output CURRENT controls of each power supply can be separately set. The output voltage controls of one power supply should be set to the desired output voltage; the other power supply should be set for a slightly larger output voltage. The supply set to the lower output voltage will act as a constant voltage source; the supply set to the higher output will act as a constant current source, dropping its output voltage until it equals that of the

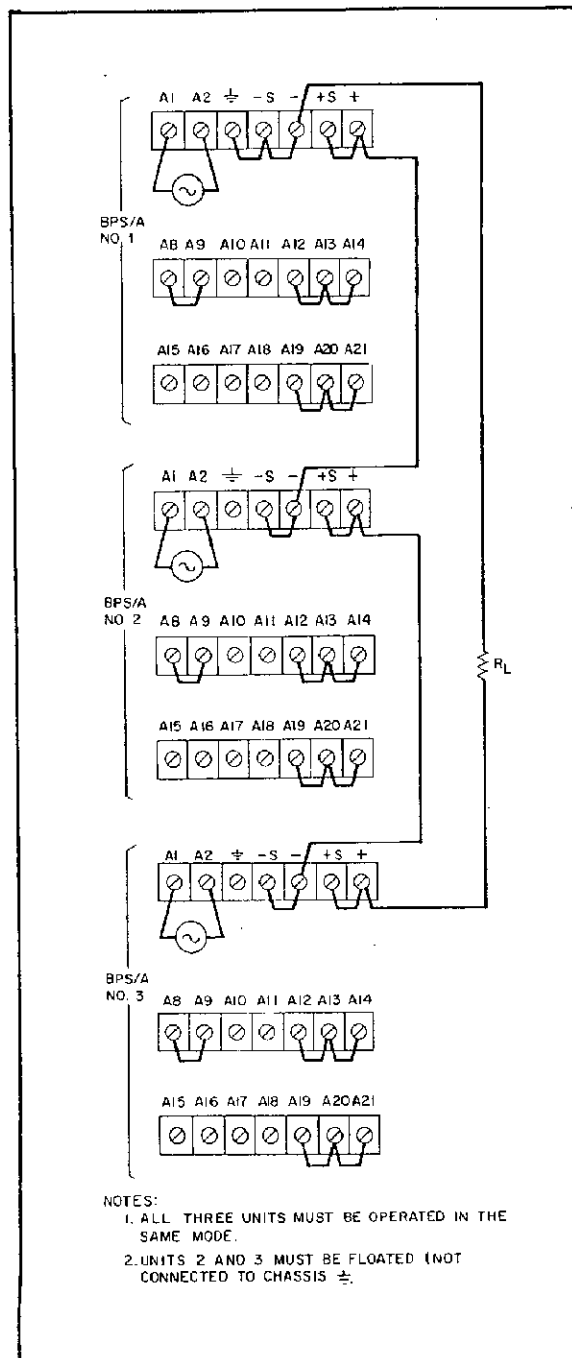

Figure 3-10. Series Connections

other supply. The constant voltage source will deliver only that fraction of its total rated output current which is necessary to fulfill the total current demand. Figure 3-11 illustrates the parallel connections for three units.

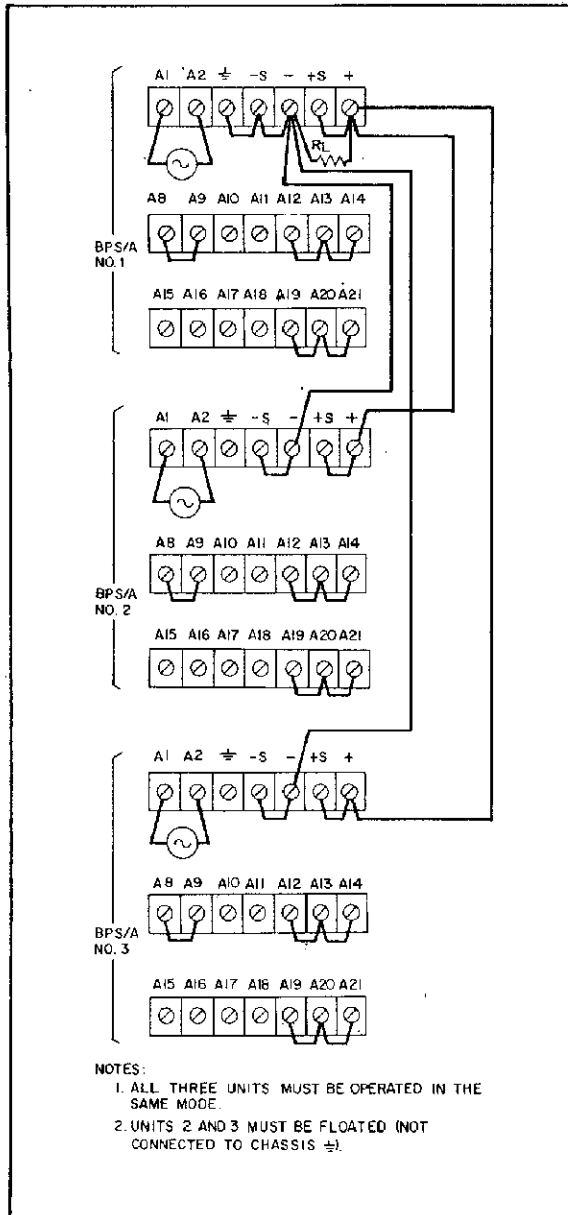

Figure 3-11. Parallel Connections

3-57 AUTO-SERIES AND AUTO-PARALLEL CONNECTIONS

3-58 The following paragraphs describe the connections required for combining BPS/A's in auto-series and auto-parallel. These connections are employed whenever it is required to extend the voltage/gain or current capability beyond one supply. For auto-series operation, the output voltage of each slave supply varies in accordance with that of

the master supply. For auto-parallel operation, complete control of the output current from one master is allowed. Diagrams are included for the strapping connections required between master and slaves for both auto-series and auto-parallel operations. In either case, the master must be in the power supply or variable gain amplifier mode and the slaves must be in the fixed gain amplifier mode. Also, for auto-series or parallel operation, the master supply's Local/Auto switch A2S1 (see Figure 3-9) must be in the Local position and each slave supply must have its Local/Auto switch in the Auto position. The diagrams show the master strapped for local programming and with an external signal applied to the amplifier input terminals. However, the same auto-series or auto-parallel connections could be used with the master strapped for remote programming. Also, with the master supply in the power supply mode, the external signal applied to the A1 and A2 terminals is internally disconnected.

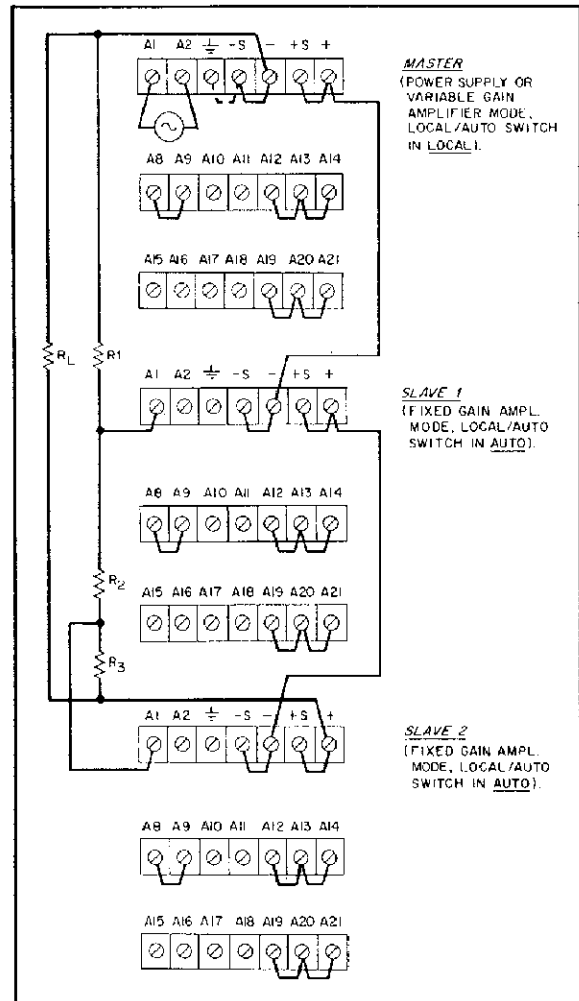

Figure 3-12. Auto-Series Connections, Three Units

3-59 Auto-Series Operation. Two or more BPS/A's can be connected in an auto-series arrangement to obtain a higher output voltage than that available from a single supply. Figure 3-12 illustrates the auto-series connections for three supplies. When this arrangement is used, the output voltage of each slave supply varies in accordance with that of the master supply; thus, the total output voltage of the combination is determined by the master supply's front panel VOLTAGE control (or remote programming input). The front panel CURRENT controls (or remote programming inputs) of all three units are operative and the current limit is equal to the lowest setting. The slave units must be floated off ground. Instruments can be operated floating up to 300 volts off ground whether operated singly or in series.

3-60 For instantaneous equal voltage sharing, resistors R_1 , R_2 , or R_3 must be equal. Since any variation in R_1 , R_2 , or R_3 will result in a change in the voltage divider ratio and hence the output of the slave supply, it is important that these resistors be stable, low temperature coefficient (20 ppm/°C or better). Also, they should have power rating of at least 10X, their actual power dissipation. The resistors should be selected at the normal operating voltage levels so that the current through them is about 1 to 2mA.

3-61 Auto-Parallel Operation. Two or more BPS/A's can be connected in auto-parallel arrangement to obtain an output current greater than that available from a single supply. Figure 3-13 illustrates the auto-parallel connections for three supplies to allow increased output current in constant voltage operation. When this arrangement is used, current sharing under all load conditions is permitted under control (front panel CURRENT control or remote programming) of the master supply. Because the CURRENT controls (or remote programming) of each slave are operative, they should be set to a maximum to prevent the slave reverting to constant current operation; this could occur if the master output current setting exceeded the slave's. For equal current sharing, the leads from R_M to the load and to the (-) terminals should be approximately equal in length. To maintain instrument accuracy and stability, R_M should be a stable, low temperature coefficient resistor of sufficient rating to prevent any appreciable self-heating (typically 1Ω, 8W, ±20 ppm/°C, ±1%).

3-62 BIPOLAR OVERVOLTAGE AND OVERCURRENT LIMIT

3-63 Bipolar overvoltage and overcurrent limit circuits prevent excessive BPS/A voltage or current outputs. The voltage limiting circuit prevents the output voltage from exceeding approximately ± 22 volts. The current limiting circuit limits the transient output current to a value approximately two times the maximum rated output of 2.0A.

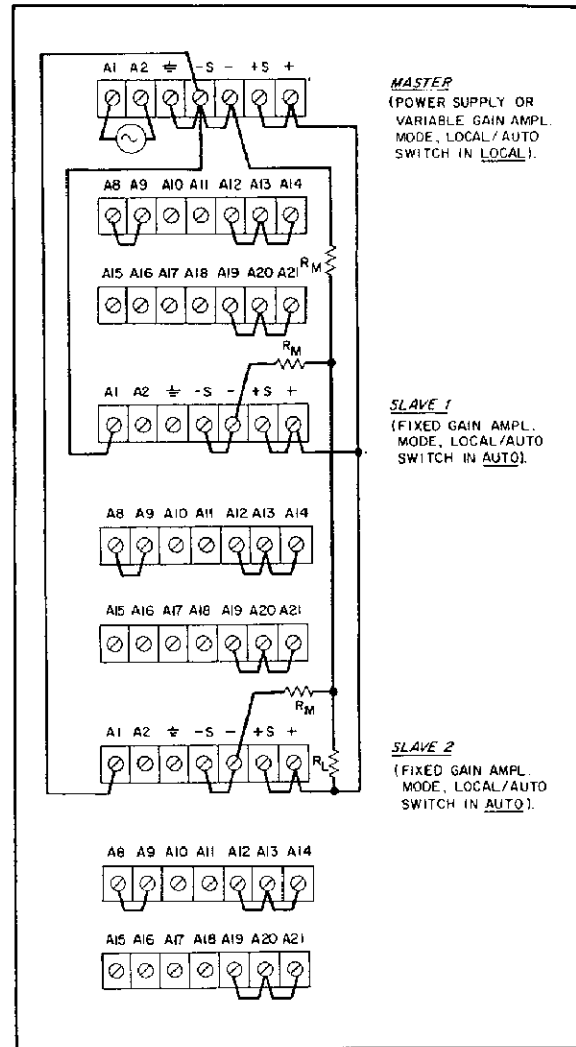

Figure 3-13. Auto-Parallel Connections, Three Units

3-64 REVERSE VOLTAGE AND CURRENT LOADING

3-65 Current limit circuits also protect the BPS/A from active loads that force energy in or out of the BPS/A (sink condition). This can appear as current flow into the HI OUT (+) terminal when the terminal is positive, or current flow out of the terminal when it is negative. Figure 3-14 shows the normal operating locus of the BPS/A. As shown, the 6825A BPS/A will limit the sink current to a value ranging linearly from 2A at 0V to 1A at 20V.

3-66 An active load can easily be accommodated by the BPS/A as long as the following precautions are adhered to:

- a. The active load must not be applied unless the BPS/A is in its active state.
- b. Program to zero output before disconnecting load.

CAUTION

*Externally applied voltage to output terminals
in excess of 25V could damage the instrument.*

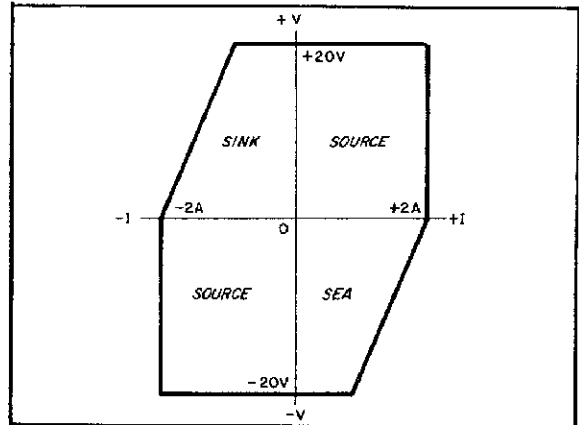

Figure 3-14. 6825A Output Ranges

SECTION IV PRINCIPLES OF OPERATION

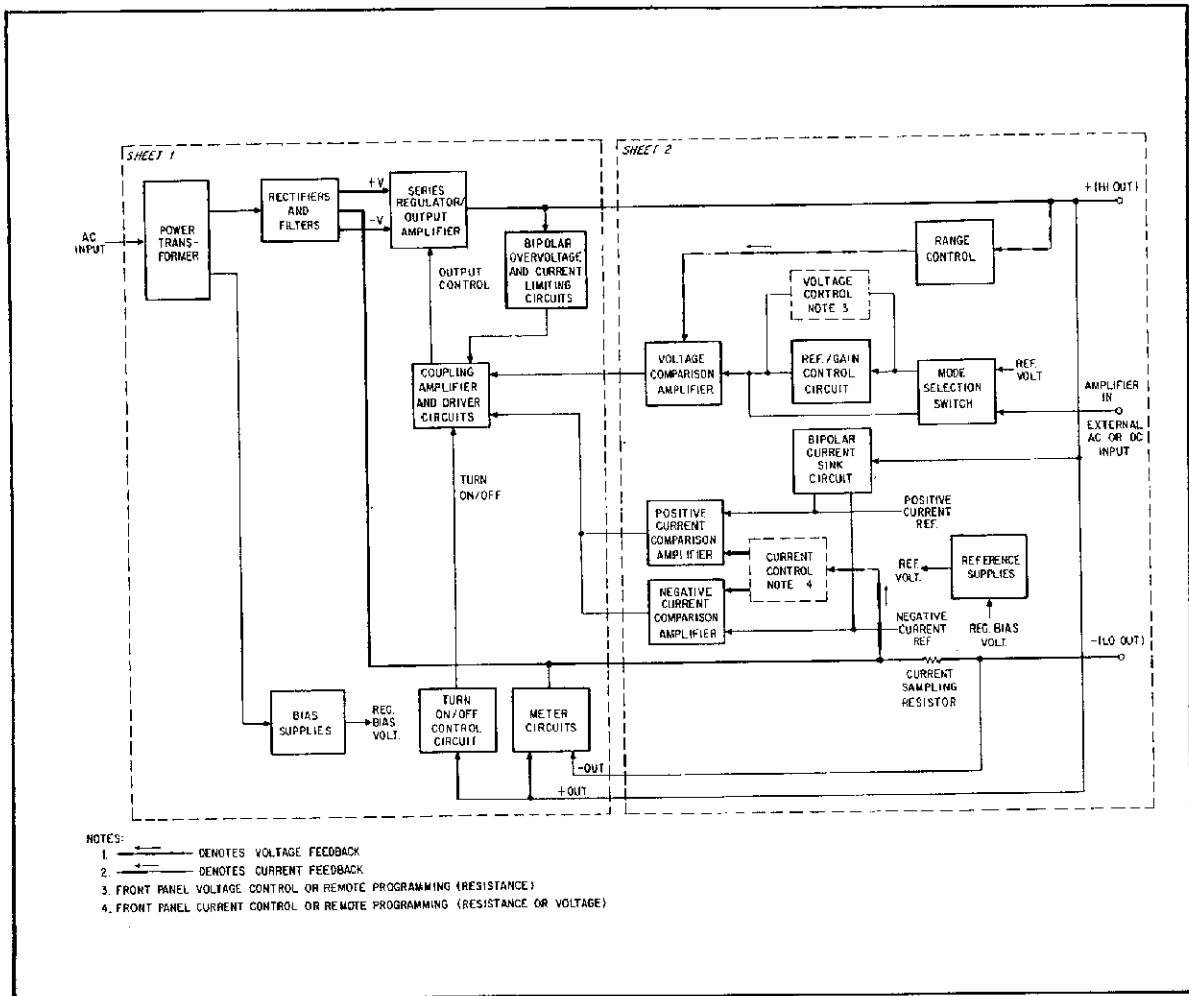

Figure 4-1. BPS/A Block Diagram

4-1 OVERALL DESCRIPTION

4-2 GENERAL

4-3 The following paragraphs provide an overall description of Bipolar Power Supply/Amplifier, Model 6825A. The BPS/A can be operated as a power supply or a power amplifier. As a power supply, the BPS/A provides a precise low noise, low drift bipolar output voltage. The output voltage can be varied from positive to negative continu-

ously through zero using the front panel VOLTAGE control or a remote programming control. A crossover feature automatically changes the supply mode from constant voltage to constant current. Constant voltage (CV)/constant current (CC) operation is described in Paragraph 4-15. The BPS/A is also capable of sinking current; that is, current from an active load can flow back into the BPS/A when the output terminal is positive or current can flow out of the output terminal when the voltage is negative. The BPS/A can sink current up to 50% of the rated current output. The BPS/A can

also function as a variable gain or fixed gain amplifier to amplify externally applied dc and ac signals. The variable gain can be controlled locally (front panel VOLTAGE control) or remotely and is accurate to within 0.1%. The variable gain amplifier is non-inverting and has a frequency response from dc to 15kHz. Total harmonic distortion is less than 0.1%. The fixed gain amplifier is inverting and has a frequency response from dc to 35kHz.

4-4 BLOCK DIAGRAM DESCRIPTION

4-5 Figure 4-1 is a basic block diagram of the BPS/A showing the major circuit blocks, together with the principle input/output signals of each block. The sheet numbers correlate the blocks shown on this diagram with the schematic sheets at the rear of the manual.

4-6 The ac line voltage is applied to the power transformer and, after being altered in level, is rectified and filtered. The resulting raw dc of both polarities is fed to the series regulator/output amplifier, which varies its conduction (positive or negative) in response to feedback signals to provide the proper output voltage or current. During power supply operation, this circuit functions as a series regulator to provide the proper output voltage. During amplifier operation it acts as an output amplifier to provide the proper gain for externally applied ac or dc signals. The MODE switch allows selection of the power supply mode or amplifier mode (fixed or variable gain). The series regulator/output amplifier is part of a feedback loop consisting of the amplifier and driver circuits, and the voltage and current comparison amplifier circuits.

4-7 The amplifier and driver circuits receive an error signal from the voltage or current comparison amplifiers in order to control the conduction of the series regulator/output amplifier transistors. A positive or negative going error signal is amplified by the appropriate amplifier and driver transistors (positive or negative) and then fed back to control the appropriate series regulator/output amplifier transistors.

4-8 During constant voltage operation, the voltage comparison amplifier compares a portion of the output voltage (feedback) with a reference voltage. In the power supply or variable gain amplifier mode, the reference voltage is received from the reference/gain control circuit. In the fixed gain amplifier mode, the reference voltage is an externally applied ac or dc signal. If the feedback and reference voltages are not equal, the voltage comparison amplifier produces an amplified error signal which is further amplified by the low level amplifier and driver circuits and then fed to the series regulator/output amplifier to control the output. In this manner, the voltage comparison amplifier main-

tains a constant output voltage and also generates the signal necessary to set the output level according to the reference voltage or the externally applied ac or dc signal. Note that the output voltage feedback signal is applied to the voltage comparison amplifier via a range control circuit. This circuit provides the proper scaling of the output in the high and low output ranges.

4-9 In the power supply mode, the voltage comparison amplifier and output amplifier (amplifiers, drivers, and series regulator) blocks can be viewed as a power operational amplifier whose inputs consist of the feedback signal and a control signal from the reference/gain control circuit block. The control signal is derived from an internal dc reference voltage which is applied to the reference/gain control circuit via the MODE selection switch. As the result of a summing action, a bipolar output can be obtained whose magnitude and polarity depend only upon the setting of the VOLTAGE control (or remote programming resistance) connected across the reference/gain control circuit (refer to Paragraph 4-43 for a detailed description of this circuit). In the variable gain amplifier mode, an external dc or ac signal is applied to the reference/gain control circuit via the MODE switch. For variable gain amplifier operation, the magnitude of the output depends upon the setting of the VOLTAGE control (or remote programming resistance) and the polarity of the output is the same polarity as the input signal. In the fixed gain amplifier mode, an external ac or dc signal is applied to the voltage comparison amplifier via the MODE switch (the reference/gain control circuit is bypassed). For fixed gain amplifier operation, the output signal is inverted. The range control circuit in the voltage feedback path allows high or low range scaling of the output in all three modes of operation. The range control circuit may be controlled locally (front panel RANGE control) or remotely (rear terminal strip). The range control circuit is described in detail in Paragraph 4-47.

4-10 The current comparison amplifiers control the switching of BPS/A operation between constant voltage and constant current (see Paragraph 4-15) and provide a constant current output when the BPS/A is operating as a constant current source. During constant current operation, positive and negative current comparison amplifiers detect any difference between the voltage drop across the current sampling resistor and a fixed stable reference. The voltage across the sampling resistor is applied to the amplifiers through the front panel CURRENT control or remote current programming control. Any change in load current whether by variation of the CURRENT control resistance (or remote current programming input) or by changes in the current through the current sampling resistor causes an error voltage proportional to the current to be applied to the amplifier and driver circuit.

Consequently, the series regulator/output amplifier conduction will be altered thereby restoring the load current to some initial value. Either the positive or the negative current comparison amplifier can be in control depending upon the polarity of the current.

4-11 The bipolar overvoltage and current limiting circuits monitor the output voltage and current. The voltage limiting circuit prevents the output voltage from exceeding approximately 10% of the maximum rated output voltage. The current limiting circuit limits the output current to a value approximately two times the nominal rated output in order to protect the instrument during the transition from constant voltage to constant current operation.

4-12 The turn-on/off circuit protects the load from power turn-on and turn-off transients by shorting the BPS/A output and disabling the amplifier and driver circuits during turn-on and turn-off.

4-13 The bias supply converts the ac input to regulated dc voltages which are used throughout the instrument for biasing purposes. Also, the reference voltages used in the voltage and current comparison circuits are derived from the bias voltage. In addition, the bias supply provides the voltage to operate the turn-on/off circuit.

4-14 Meter circuits are provided for monitoring the BPS/A output voltage and current (ac and dc). Compensation circuits are included for meter loading effects.

4-15 CONSTANT VOLTAGE/CONSTANT CURRENT OPERATION

4-16 In order to maintain a constant voltage output, the voltage comparison amplifier tends to achieve zero output impedance by altering the output current whenever the load resistance changes. In order to maintain a constant output current, the current comparison amplifiers attempt to achieve infinite output impedance by changing the output voltage in response to any load resistance variations. Thus, it should be noted that the voltage and current comparison amplifiers cannot operate simultaneously. For any given value of load resistance, the BPS/A must act either as a constant voltage or a constant current supply. Transfer between operation is accomplished automatically by switchable decoupling circuits at a value of load resistance equal to the ratio of the output voltage control (VOLTAGE control or remote voltage programming control) setting and the current control (CURRENT control or remote current programming control) setting. Figure 4-2 shows the output characteristics of a constant voltage/constant current power supply when operated within the bipolar output voltage and current ranges. With no load attached ($R_L = \infty$), $I_{OUT} = 0$, and $E_{OUT} = E_S$, the front panel voltage or remote program-

ming control setting. When a load resistance is applied to the output terminals of the power supply, the output current increases, while the output voltage remains constant; point D thus represents a typical constant voltage operating point. Further decreases in load resistance are accompanied by further increases in I_{OUT} with no change in the output voltage until the output current reaches I_S , a value equal to the front panel current or remote programming control setting. At this point the supply automatically changes its mode of operation and becomes a constant current source; still further decreases in the value of load resistance are accompanied by a drop in the supply output voltage with no accompanying change in the output current value. With a short circuit across the output load terminals, $I_{OUT} = I_S$ and $E_{OUT} = 0$.

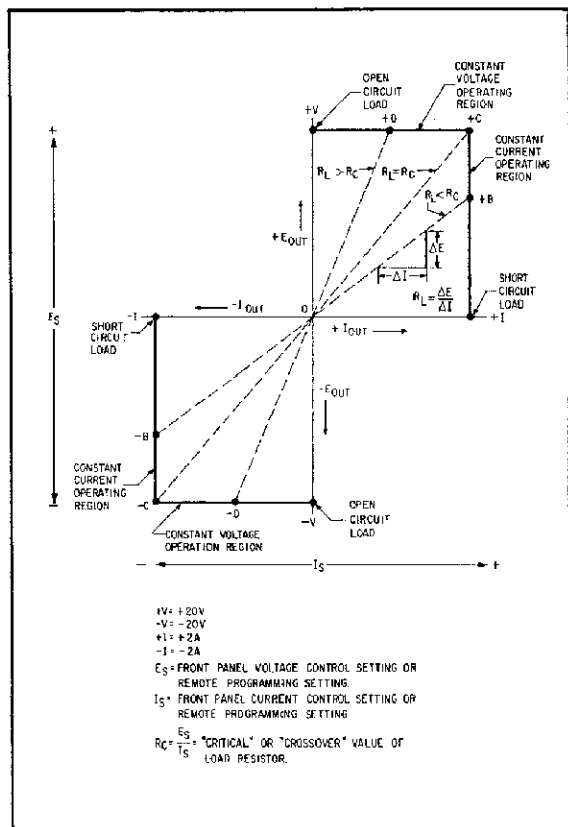

Figure 4-2. CV/CC Operating Locus

4-17 Thus, at voltage and current settings within the bipolar ranges, the "crossover" value of load resistance can be defined as $R_C = E_S / I_S$. Adjustment of the voltage and current settings permits this "crossover" resistance R_C to be set to any desired value within the rating of the instrument. If the magnitude of R_L is greater than R_C , the supply is in constant voltage operation.

4-18 DETAILED CIRCUIT DESCRIPTIONS

4-19 GENERAL

4-20 The following paragraphs provide detailed circuit descriptions of BPS/A Model 6825A. The descriptions are based on simplified schematic of Figure 7-1, and the detailed schematic of Figure 7-2 (Sheets 1 and 2). The simplified schematic illustrates, in simplified form, the circuitry depicted on Sheets 1 and 2 of Figure 7-2. The sheet numbers on Figure 7-1 correlate the simplified circuits with the circuits on the detailed schematic. The simplified schematic is provided for ease of understanding and should be referred to in conjunction with the detailed schematic. Sheet 1 of Figure 7-2 illustrates the output power amplifier and input power circuits, and Sheet 2 illustrates the voltage and current control circuits.

4-21 OUTPUT POWER AMPLIFIER CIRCUITS (Figure 7-2, Sheet 1)

4-22 **AC Input.** AC input power is applied to the chassis mounted power transformer T1 via the power module on the rear of the unit and the LINE ON switch S1 on the front panel. The power module contains fuse F1 (1A for 115Vac or .5A for 230Vac input power) and a slide switch for connecting 115 or 230Vac to the primary of the power transformer. The power transformer secondary provides the proper magnitude ac inputs to the rectifier-filter and to the bias supply.

4-23 **Rectifier-Filter.** The rectifier-filter circuits, contained on the interconnect and power supply board A1, provide the main dc power outputs. These circuits consist of rectifier diodes arranged in full-wave center-tapped rectifier configurations with associated filter capacitors and bleeder resistors to provide ± 35 and ± 45 volt raw dc outputs. The front panel LINE ON indicator DS1 is connected across the +35 volt output to indicate when the BPS/A is turned on. The ± 35 volt outputs are the main input lines to the series regulator/output amplifier. The ± 45 volt outputs are the bias supply voltages for the amplifier and driver circuits on board A3.

4-24 **Bias Supply.** The bias supply circuit provides stable ± 15 volt outputs which are used throughout the instrument for biasing purposes and to develop the reference voltages. The bias supply also provides 20 volt (filtered and unfiltered) auxiliary outputs. Two series regulator type circuits maintain the ± 15 volt outputs constant. Since the circuits are identical, only the +15 volt circuit is discussed. Transistor A1Q2 is a voltage comparison circuit that compares the +15 volt output with a fixed reference voltage. The +15 volt

output is applied to the base circuit of A1Q2 through resistors A1R29 and A1R30, whereas the reference voltage is furnished in the emitter circuit by A1VR1. If the +15 volt output changes, voltage comparator A1Q2 produces an error signal which is applied to the base of series regulator A1Q1. The error signal causes A1Q1 to change its conduction so as to correct the output voltage.

4-25 **Series Regulator/Output Amplifier.** NPN power transistors Q1 through Q4, mounted on the heat sink assembly, are utilized as series regulators during power supply operation and as a single ended push-pull amplifier during amplifier operation.

4-26 During power supply operation, parallel connected transistors Q1, Q2, and Q3, Q4 serve as series control elements in the positive and negative output lines, respectively. The series regulators are controlled by the positive and negative driver circuits on board A3. When the positive driver circuits are in control, the series regulators Q1 and Q2 are conducting and the series regulators Q3 and Q4 are turned off. For this condition, the supply furnishes a positive output. The reverse is true when the negative driver circuits are in control; Q3 and Q4 are turned on, Q1 and Q2 are turned off, and the supply provides a negative output.

4-27 Note that NPN power transistors Q1 and Q2 and associated NPN driver transistors A3Q12 and A3Q14 through A3Q16 are connected as cascaded emitter followers which respond to a positive going signal. In order to respond to negative going signals, NPN power transistors Q2 and Q3 are connected with PNP driver transistors A3Q13 and A3Q17 through A3Q19 in a pseudo-PNP configuration using local feedback. This configuration allows NPN power transistors to be employed as series control elements for negative outputs.

4-28 During amplifier operation, the transistors serve as a single-ended, push-pull output amplifier. Although the schematic shows Q1, Q2 and Q3, Q4 drawn as a conventional series regulator, the circuit could be redrawn as a push-pull amplifier without changing any of the connections. The output amplifiers are biased for class AB operation and are connected in a complementary configuration.

4-29 **Coupling Amplifier and Driver Circuits.** The coupling amplifier and driver circuits on board A3 amplify the error signal received from the voltage and current control circuits on board A2. This amplified signal controls the conduction of the series regulator/output amplifier transistors, thus controlling the amplitude and polarity of the BPS/A output. The amplifier and driver circuits consist of positive amplifier and

driver stages (Q6-Q8, Q12, Q14-Q16), and negative amplifier and driver stages (Q9-Q11, Q13, Q17-Q19) on board A3.

4-30 The error signal from the voltage or current control circuits is applied to the positive and negative voltage control amplifier circuits on board A3. For a positive going control signal the positive amplifier conducts more and the negative amplifier less. The reverse is true for a negative going control signal. Since the positive and negative sections of the amplifier and driver are symmetrical, only the positive section is discussed in detail.

4-31 The positive voltage coupling amplifier is comprised of transistor stages Q6, Q7 and Q8. Coupling amplifier stage Q7 serves as a "level changing" transistor coupling the error signal to the output driver circuits. The gain of the coupling amplifier is about 1.6X. Notice that the supply voltages for the input circuits are low level and referenced to ② common (see Figure 7-2, sheet 2). The other amplifier and driver stages, however, use high-level supply voltages (± 35 and $\pm 45\text{V}$) that are referenced to ① common. Transistor Q8, in the emitter circuit of coupling amplifier Q7, serves to minimize unwanted ground current from flowing in the low output sense terminal. The negative going output of coupling amplifier stage Q7 is applied to voltage amplifier Q6. The positive (Q6-Q8) and negative (Q9-Q11) coupling amplifiers provide a combined gain of approximately 36X. Each section (positive and negative) provides a gain of approximately 18X. As a result of the voltage amplification, the voltage across R28 biases the positive (NPN) driver transistors (Q12, Q14 through Q16) into conduction provided that a turn-on condition is present (see Paragraph 4-35). The positive driver transistors drive the positive series regulator/output amplifier transistors Q1 and Q2. These transistors are connected in series with the +35V supply voltage and thus control the BPS/A output. Capacitors C9, C10 and resistor R27 form networks which in addition to capacitor C11 connected between the HI and LO output terminals help to shape and stabilize the BPS/A output response. Additional local stabilization is afforded by network (C14, R53) in the positive driver circuits, and network (C15, R55) in the negative driver circuit.

4-32 The negative section of the power amplifier operates in the same manner as that described above except that it is activated by negative going error signals and provides negative BPS/A outputs. The negative section is comprised of negative voltage coupling amplifier stages (Q9-Q11), and negative (PNP) driver transistors (Q13, Q17 through Q19).

4-33 At zero output voltage, both the positive and negative driver sections are conducting a small current through diodes CR14, CR15, and CR16 to provide the voltage drop necessary to forward bias Q12 and Q13 simultaneously. This eliminates "dead spots" when the BPS/A is programmed through zero.

4-34 Bipolar Overvoltage and Current Limiting Circuits.

The bipolar overvoltage and current limiting circuits are located on board A3. Zener diodes VR1 and VR2, connected in the base circuits of Q12 and Q13, prevent the output voltage from exceeding approximately ± 22 volts. Diodes CR20, CR21, and CR22 form current limiting circuits. These diodes monitor the output current flowing through the series regulator/output amplifier and limit the transient current to a value approximately 2 times the nominal rated output during the transition from the constant voltage to constant current operation.

4-35 Turn On/Off Circuit. The turn on/off circuit is comprised of transistor stages Q1 through Q5 on board A3 and relay K1 on board A1. The purpose of this circuit is to limit turn on/off transients which might affect the load. To accomplish this, the output is clamped at a low level when the BPS/A is turned on or off.

4-36 Before power is applied to the BPS/A, relay A1K1 is deenergized connecting the HI OUT (+) to LO OUT (-) line via ② common through resistor R60 (1 Ω , 3W). Also, with A1K1 deenergized, an open circuit is present at the emitter of A3Q1. When power is applied, relay A1K1 will not become energized for approximately 0.2 seconds due to RC time constant (R32, R37, C2). Thus, the open circuit condition is present at the emitter of A3Q1 at initial turn-on. The +20V (unfiltered) supply voltage, however, causes transistors A3Q4 and A3Q5 to be forward biased. Consequently, transistors A3Q2 and A3Q3 are turned on drawing current away from the bases of driver transistors A3Q12 and A3Q13 respectively, effectively turning these stages off. After the delay (approximately 0.2 seconds) has elapsed, relay A1K1 becomes energized removing the ② common path to the HI OUT terminal and connecting ② common to the emitter of A3Q1 causing the collector of A3Q1 to drop to about 0.1V. For this condition, the forward bias for transistor A3Q4 is removed causing A3Q4 to turn off which in turn causes transistors A3Q2 and A3Q3 to turn off removing the clamping action at the bases of A3Q12 and A3Q13. Driver transistor A3Q12 or A3Q13 will now conduct depending upon the magnitude and polarity of the error signal.

4-37 At turn-off, the +20V (unfiltered) supply voltage is removed but relay A1K1 remains energized for approximately .1 seconds due to stored energy. When it becomes deenergized, the ② common connection from the emitter of A3Q1 is removed and the HI OUT line is connected to the LO OUT line via R60. However, the +20V (filtered) supply voltage is present for some time causing A3Q4 and A3Q5 to be forward biased. This drives transistors A3Q2 and A3Q3 into full conduction drawing current away from the bases of A3Q12 and A3Q13 respectively, effectively turning these stages off during the decay of stored voltages.

4-38 Meter Circuits. The meter circuits provide continuous indications of output voltage and current. VOLTAGE-METER M1 is connected across the BPS/A output and can be used to monitor ac or dc output voltage depending upon the position of switch A1S1. With A1S1 in the AC position, diode A1CR20 rectifies the ac output voltage in order to obtain an rms reading. Variable resistors A1R8 (dc adjust) and A1R13 (ac adjust) are used when calibrating the voltmeter. CURRENT-METER M2 is connected across the current sampling resistor A2R27 whose voltage drop is proportional to the output current. Meter M2 can measure ac or dc output current depending upon the position of switch A1S2. With A1S2 in the ac position, current meter driver A2U5 and diode CR18 amplify and rectify the ac input (applied through C13) in order to obtain an rms reading. Variable resistors A1R20 (dc adjust) and A1R18 (ac adjust) are used when calibrating the ammeter.

4-39 Each meter switch provides two ranges, with a 10:1 ratio for each of the dc and ac functions. Resistor R54 is a thermistor which in conjunction with R55 compensates for temperature effects.

4-40 VOLTAGE AND CURRENT CONTROL CIRCUITS (Figure 7-2, Sheet 2)

4-41 The voltage control circuits consist of the mode selection, voltage reference/gain control, and voltage comparison circuits. The current control circuits consist of positive and negative current comparison circuits. Each of these main circuits and associated components are described in the following paragraphs.

4-42 Mode Selection. The front panel MODE switch (sections A5S2A and A5S2B) allows the selection of the power supply, variable gain amplifier, or fixed gain amplifier operating mode. In the power supply mode, a positive dc reference voltage is converted to a variable bipolar dc output voltage by operational amplifier techniques. In the variable gain amplifier mode, an externally applied dc or ac signal is attenuated or amplified by the voltage reference/gain control circuit for application to the voltage comparison amplifier. In the fixed gain amplifier mode, the voltage reference/gain control circuit is bypassed and an externally applied dc or ac signal is applied directly to the voltage comparison amplifier. Each of the above conditions is described in subsequent paragraphs.

4-43 Voltage Reference/Gain Control Circuit. In the power supply mode, voltage reference/gain control amplifier A2U2 provides a signal (0 to -10V) at the junction of A2R6 and A2R7 depending upon the setting of the front panel VOLTAGE control A5R2 (or remote programming input). With rear terminals A8 and A9 shorted and A10 open, local control is allowed through A5R2. Remote con-



trol is allowed by connecting a programming resistance between A9 and A10 with A8 open.

4-44 A fixed +5.12V reference voltage, derived from the +15V regulated bias supply, zener diode A2VR4, and resistors A2R58, A2R59, is applied to the inverting input (pin 2) of A2U2 through section S2A of the MODE switch and A1R42 and A2R4. Depending upon the front panel VOLTAGE control (A5R2) setting (or remote programming input), A2U2 provides a 0 to -10V output. This output is summed at the junction of A2R6 and A2R7 with the +5.12V reference which is applied through section S2B of the MODE switch. This summing action provides a variable bipolar voltage output.

4-45 In the variable gain amplifier mode, the +5.12V reference is removed and an external signal (dc or ac), applied to the HI IN (A1) and LO IN (A2) terminals, is fed to the inverting input of A2U2. For this mode, the VOLTAGE control A5R2 (or remote programming input) controls the gain of A2U2 from 0 to 2X and summing with the dc references is not performed.

4-46 Diodes A2CR1 and A2CR2 limit the maximum input to the A2U2 amplifier protecting it from excessive voltage excursions. Variable resistors A1R1 (V ZERO on front panel), A2R58 (course adjustment), and A2R59 (fine adjustment) in the reference voltage circuits are used to calibrate zero output voltage and the reference voltages.

4-47 Voltage Comparison Amplifier. Voltage comparison amplifier A2U1 continuously compares the output voltage with a reference voltage. The inverting input (pin 2) of A2U1 is the summing point which receives a portion of the output voltage (feedback voltage) from the (+S) terminal and the variable reference voltage from A2U2 or from the HI and LO IN terminals (A1 and A2). The non-inverting input (pin 3) of A2U1 receives a fixed dc bias. If a difference exists between these inputs, the comparison amplifier produces an "error" voltage at pin 6 whose amplitude is proportional to the difference. The error signal is then applied to the series regulator/output amplifier via the coupling amplifier and driver circuits. The feedback voltage is applied to the summing point (pin 2 of A2U1) from the high sense terminal (+S) via a range network consisting of resistors A2R9, A2R16, A2R42 and relay A2K3. Relay A2K3 changes the range of the power amplifier by changing the feedback resistance by a factor of 4. In the X4 range, resistors A2R9, A2R16, and A2R42 are in the feedback path. In the X1 range resistors, A2R9 and A2R42 are shorted out. Relay A2K2 switches in the proper value equalizing network for each range; A2C7 and A2R14 in the X4 range or these components in parallel with C6 and R15 in the X1 range. Relays A2K2 and A2K3 are controlled by the RANGE switch A5S2C (positions X1, X4, or REMOTE). In the

X4 position, the junction of A2K2, K3, and CR4 anode is removed from  return which disables the relays to their normally open condition. However, with A5S2C in the X1 position, the return to  is completed and the relays are activated from the +15Vdc bias supply. With RANGE switch A5S2C in the REMOTE position, remote selection of the X1 or X4 range is allowed via rear terminal A11.

4-48 Changes in the error signal magnitude and polarity instantaneously cause the summing point potential to change. This change causes comparison amplifier A2U1 to provide the proper correction voltage to the low level amplifier and driver circuits. The correction voltage levels at the low level amplifier input are from approximately -2.5V to -4.5V and correspond to the output voltage range of +30V to -20V. A correction voltage of approximately -3.5V corresponds to an output voltage of 0V. Zener diode A2VR8, diodes A2CR20, and CR21, and resistor A2R41 prevent A2U1 from going deep into saturation. Diodes A2CR18 and A2CR19 limit the maximum input to the comparison amplifier thus protecting it from overvoltage conditions. Variable resistors A2R60 and A2R61, connected to the +6.2V and -6.2V reference voltage circuits through resistors A2R36 to A2R39 and A2R51 through A2R54, are used for output zero and offset adjustments. Relay A2K1 opens the input path to A2U1 when the BPS/A is remotely controlled and the programmed data is changed, thus, preventing data transients from affecting the output voltage. The AUTO/LOCAL switch A2S1 in the feedback loop is normally left in the LOCAL position. The AUTO position is used for auto-series or auto-parallel operation when the summing junction of the error amplifier must be available for external error signal connections from other units.

4-49 Output Voltage/Gain Control Summary. As stated previously, the BPS/A output voltage is developed utilizing operational amplifier techniques. In the power supply mode, the bipolar output characteristic is developed through the summing of the internal fixed reference voltage (V_{REF}) and a voltage which is dependent only on a single programming control (VOLTAGE control A5R2 or a remote programming resistance). E_O is given by the following equations for the X1 and X4 ranges:

$$E_O = +V_{REF} \left(\frac{R_{PV}}{A1R42} \times \frac{R_F}{A2R6} \right) - V_{REF} \left(\frac{R_F}{A2R7} \right)$$

where:

$R_{PV} = 0$ to $20.48K\Omega$ (front panel VOLTAGE control or remote programming resistance)

$R_F =$ feedback resistance (A2R16, or A2R9 + A2R16 + A2R42) = $10.24K\Omega$ or $40.96K\Omega$ (X1 or X4 range respectively)

A1R42 = A2R6 = A2R7 = $10.24K\Omega$

$V_{REF} = 5.12V$

In the X1 range:

$$E_O = 5.12V \left(\frac{R_{PV}}{10.24K} \times \frac{10.24K}{10.24K} \right) - 5.12V \left(\frac{10.24K}{10.24K} \right)$$

$$E_O = 5.12V \left(\frac{R_{PV}}{10.24K} - 1 \right)$$

therefore; $E_O = -5.12V$, if $R_{PV} = 0$

$E_O = 0$, if $R_{PV} = 10.24K$

$E_O = +5.12V$, if $R_{PV} = 20.48K$

In the X4 range:

$$E_O = 5.12V \left(\frac{R_{PV}}{10.24K} \times \frac{40.96K}{10.24K} \right) - 5.12V \left(\frac{40.96K}{10.24K} \right)$$

$$E_O = 5.12V \left(\frac{4R_{PV}}{10.24K} - 4 \right)$$

therefore; $E_O = -20.48V$, if $R_{PV} = 0$

$E_O = 0$, if $R_{PV} = 10.24K$

$E_O = +20.48V$, if $R_{PV} = 20.48K$

4-50 In the variable gain amplifier mode, the BPS/A controls the gain of an externally applied dc or ac signal. For this mode, the internal fixed dc reference voltage is disconnected and the reference/gain control circuit attenuates or amplifies the externally applied signal from 0 to 2X depending upon the setting of the VOLTAGE control A5R2 (or remote programming resistance). The feedback resistor(s) provide a gain of 1 in the X1 range and a gain of 4 in the X4 range. Consequently, the variable gain is from 0 to 2X in the X1 range and from 0 to 8X in the X4 range. In the fixed gain amplifier mode, the gain is controlled only by the feedback resistor(s) which provide a times 1 gain in the X1 range and a times 4 gain in the X4 range.

4-51 Current Comparison Amplifiers. Current comparison amplifiers A2U3 (positive) and A2U4 (negative) control BPS/A operation between constant voltage and constant current by continuously monitoring the voltage drop across the current sampling resistor (A2R27). This voltage drop is applied to the current comparison amplifiers via the front panel CURRENT control A5R1 or the remote programming input terminals. The other input to the current comparison amplifiers is a stable fixed reference current. Any disturbance in load current whether by variation of the CURRENT control (or remote programming input) or in the current flow through the sampling resistor (as in line or load change) will cause a corrective voltage to alter the appropriate series regulator (positive or negative) conduction thereby restoring the load current to some initial value.

4-52 Positive current comparison amplifier A2U3 monitors positive output currents and negative current comparison amplifier A2U4 monitors negative output currents. These

amplifiers control switching the BPS/A between constant voltage and constant current operation. In constant voltage operation, they are in saturation, reverse biasing A2CR13 and A2CR14 and preventing any current control action. In constant current operation, they become linear comparison amplifiers allowing BPS/A operation as a constant current source. Also, for current sink conditions, they limit the output current to 1/2 maximum rated output through separate control circuits consisting of A2CR3, CR4, CR7, CR8, CR11, CR12, R28, and R29. Because the two comparison amplifiers are similar, only the positive current comparison amplifier is described in detail.

4-53 The voltage drop across the current sampling resistor A2R27 is applied to pin 3 of A2U3 via the front panel CURRENT control A5R1 (or the remote programming input terminals). Current control through A5R1 (local control) is achieved with rear terminals A12, A13, and A14 strapped together for positive currents and with A19, A20, and A21 strapped together for negative currents. External digital resistance control can be implemented by connecting the proper resistances between A13, A14 (strapped together) and A18 for positive currents, and between A20, A21 (strapped together) and A18 for negative currents. Another method of control of the current is through voltage programming via terminals A14 and A18 and A20 and A18 for positive and negative currents respectively.

4-54 A fixed reference current is applied to the other input (pin 2) of A2U3. During constant voltage operation, A2U3 is saturated causing the output to be positive. Zener diode A2VR5 and diode A2CR5 clamp the output at +7.5V preventing A2U3 from going too far into saturation. For this condition, diode A2CR14 is back biased and PNP switching transistor A2Q5 is turned off causing A2CR9 and A2CR10 to be forward biased. With A2CR14 back biased, constant voltage operation is enabled and constant current operation is disabled (the negative constant current diode A2CR13 must also be back biased for this condition). With A2CR9 forward biased, transistor A1Q1 is turned-on allowing capacitor A2C9 to charge during constant voltage operation. This will speed up the transition from constant volt-

age to constant current operation. With A2CR10 forward biased, the CURRENT MODE indicator DS1 is off (A2Q2 turned-on and A2Q3 turned-off) and the FLAG output is disabled (low level, FLAG output with A2Q4 turned-on). Networks consisting of A2C11, R63, R64 and A2C12, R65, R66 are included in the inputs of A2U3 and A2U4 respectively. These networks in conjunction with local compensation represented by A2C9, R46, and R47 (common to both A2U3 and A2U4) provide response stabilizing compensation.

4-55 If the output current increases above the set value, the input to pin 3 of A2U3 becomes less positive. For this condition, the output (pin 6) of A2U3 goes negative forward biasing A2CR14. With A2CR14 forward biased, the BPS/A switches from constant voltage to constant current operation and an error signal is applied to alter the series regulator (positive) conduction and maintain the output current at the desired value. Also, for this condition, A2Q5 is switched on back biasing diodes A2CR9 and A2CR10. With A2CR9 back biased, A2Q1 is turned-off. With A2CR10 back biased, the CURRENT MODE indicator DS1 lights (A2Q2 off, A2Q3 on) and the FLAG output is enabled (A2Q4 turned off providing a high FLAG output).

4-56 During current sinking operations, the input to A2U3 (negative voltage case) is altered causing the current being sunk to increase or decrease in response to the voltage magnitude of the active load. When the output voltage is negative, diodes A2CR3 and A2CR12 become forward biased through A2R28 altering the reference current to A2U3. This condition in conjunction with the voltage change across A2R27 will cause the output of A2U3 to adjust the drive to the appropriate output transistors to limit the imposed load current. The operation of A2U4 is similar in principle for the positive voltage case. Front panel controls +I ZERO (A1R2) and -I ZERO (A1R3), in the positive and negative current reference circuits are used to adjust the respective zero for programming accuracy. Variable resistors A1R19 and A2R21 are used to calibrate the positive and negative current references.

SECTION V MAINTENANCE

5-1 INTRODUCTION

5-2 The performance checks (Paragraph 5-5) should be made to check the operation of the BPS/A after repairs or for periodic maintenance. These checks are also suitable for incoming inspection. If a fault is detected in the BPS/A while making the performance check or during normal operation, proceed to the troubleshooting procedures (Paragraph 5-60). After repair and replacement (Paragraph 5-84), perform any necessary adjustments and calibrations (Paragraph

5-98). Before returning the BPS/A to normal operation, repeat the performance check to ensure that the fault has been properly corrected and that no other faults exist. Before performing any maintenance checks, turn on the BPS/A and allow a half-hour warm-up.

5-3 TEST EQUIPMENT REQUIRED

5-4 Table 5-1 lists the test equipment required to perform the various procedures described in this section.

Table 5-1. Test Equipment Required

TYPE	REQUIRED CHARACTERISTICS	USE	RECOMMENDED MODEL
Differential Voltmeter	Sensitivity: 500 μ V full scale (min.). Input impedance: 100M Ω (min.).	Measure dc voltages; calibration procedures. Measure amplifier gain (Option 001).	HP345013 with Option 001
Digital Voltmeter	Accuracy: 0.004% Sensitivity: 1 μ V, floating input.	Measure dc voltages, calibration procedures.	HP3462A or HP3420B
Oscilloscope	Sensitivity and bandwidth: 1mV/cm and 50MHz.	Measure ripple; display transient recovery waveforms; measure noise spikes. Measure response.	HP180A plus 1801A, and 1821A, plug-ins.
Function Generator	100Hz squarewave and sinewave.	Measure frequency response and output impedance.	HP3310A
Distortion Analyzer	Accuracy: \pm 3% from 10Hz to 1MHz.	Measure amplifier distortion.	HP331A
Variable Voltage Transformer	Current rating: 2A; Range: 90–130Vac; Equipped with voltmeter accurate within 1 volt.	Vary ac input for high line to low line regulation.	
Repetitive Load Switch	Rate: 60–400Hz; 2 μ sec rise and fall time.	Measure transient response.	See Figure 5-4.
Current Sampling Resistor	Value: 1 Ω \pm .1%, 24W	Measure output current, calibrate ammeter.	
Resistive Loads	Value: See Figure 5-1, \pm 1%, 50W	Load resistors.	
Terminating Resistors	Value: 50 ohms, 1/2W, \pm 5%, non-inductive, 4 required.	Noise spike measurement.	
Blocking Capacitors	Values: 0.01 μ F, 100Vdc, 2 required; 1000 μ F, 60Vdc, 1 required.	Noise spike measurement; output impedance measurement.	
Programming Resistors	10.24K \pm .05% 20.48K \pm .05%		0811-2958 0811-2959 (Micro Ohm Type 132F)

5-5 PERFORMANCE TEST

5-6 The following test can be used as an incoming inspection check and appropriate portions of the test can be repeated either to check the operation of the instrument after repairs or for periodic maintenance tests. The tests are performed using a 115Vac, 60Hz, single phase input power source.

5-7 POWER SUPPLY MODE TESTS

5-8 All measuring devices must be connected to the rear sensing terminals of the supply and not to the front output terminals if maximum accuracy is to be obtained in the following measurements. In addition, the measuring devices must be connected as close to the sensing terminals as possible. This is particularly important when measuring the transient response, regulation, or ripple of the power supply. Note that under no circumstances should the measuring instruments be connected across the load. A measurement made across the load includes the impedance of the leads to the load and such lead lengths can easily have an impedance several orders of magnitude greater than the supply impedance, thus invalidating the measurement.

5-9 To avoid mutual coupling effects, each monitoring device must be connected to the sensing terminals by a separate pair of leads. Twisted pairs or shielded two-wire cables should be used to avoid pickup on the measuring leads. The load resistor should be connected across the output terminals as close to the supply as possible. When measuring the constant voltage performance specifications, the current controls should be set well above (at least 10%) the maximum output current which the supply will draw, since the onset of constant current action will cause a drop in output voltage, increased ripple, and other performance changes not properly ascribed to the constant voltage operation of the supply.

5-10 **DC Voltage Output and Voltmeter Accuracy.** To check the DC voltage output and voltmeter accuracy, proceed as follows:

NOTE

The CURRENT MODE light should be off during this test.

- Connect high range load resistor (R_L) across output terminals (see Figure 5-1).
- Connect DVM across +S and -S terminals.
- Set BPS/A front panel controls as follows:
 MODE switch: POWER SUPPLY
 RANGE switch: X4
 VOLTAGE control: midposition

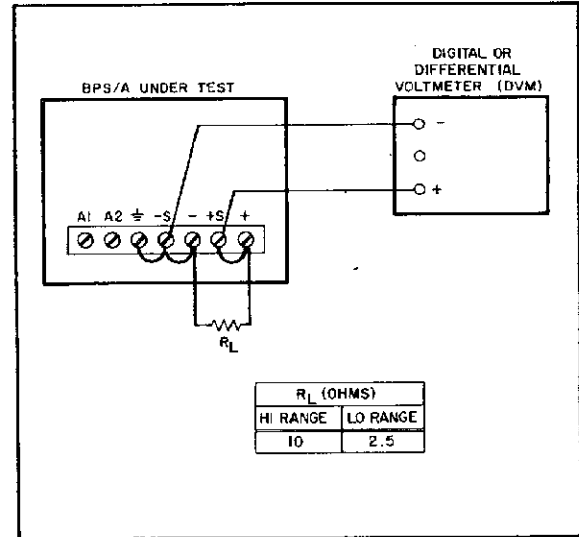

Figure 5-1. Power Supply Mode Test Setup

- CURRENT control: fully clockwise
 VOLTAGE METER: high range DC
 CURRENT METER: high range DC
- Turn on BPS/A and allow a five-minute warm-up period.
 - Turn VOLTAGE control clockwise until DVM indicates +20V.
 - Observe that front panel voltmeter reads +20V \pm 0.6V.
 - Turn VOLTAGE control counterclockwise until DVM indicates -20V.
 - Observe that front panel voltmeter reads -20V \pm 0.6V.
 - Turn off BPS/A. Change load resistor R_L to low range value (see Figure 5-1) and set RANGE switch to X1.
 - Repeat steps (d) through (h) for following DVM and front panel voltmeter readings (use low range DC scale).
- | DVM | Voltmeter |
|---------|---------------------------------|
| +5V/-5V | +5V \pm 150mV/-5V \pm 150mV |

5-11 Source Effect (Line Regulation).

Definition: The change ΔE_{OUT} in the static value of dc output voltage resulting from a change in ac input voltage over the specified range from low line (usually 104/208 volts) to high line (usually 127/254 volts), or from high line to low line.

NOTE

The CURRENT MODE light should be off during this test.

- 5-12 To check the line regulation, proceed as follows:
- Connect the test setup shown in Figure 5-1. Use high range (X4) load resistor value.
 - Connect variable auto transformer between the input power source and the BPS/A power input.
 - Adjust variable transformer for a 104 volts ac input.
 - Set BPS/A front panel controls as follows:

MODE switch:	POWER SUPPLY
RANGE switch:	X4
VOLTAGE control:	midposition
CURRENT control:	fully clockwise
VOLTAGE METER:	high range DC
CURRENT METER:	high range DC
 - Connect a DVM to the -S and +S terminals of the BPS/A.
 - Turn on BPS/A and adjust VOLTAGE control clockwise for maximum rated positive output voltage (high range) as indicated on DVM.
 - Adjust variable auto transformer for a 127 volts ac input.
 - Reading on DVM should not vary from reading in step (f) by more than 4mV.
 - Set variable auto transformer for a 104Vac input.
 - Adjust VOLTAGE control counterclockwise for maximum rated negative high range output voltage, as indicated on DVM.
 - Adjust variable auto transformer for a 127Vac input.
 - Reading on DVM should not vary from reading in step (j) by more than 4mV.
 - Turn off BPS/A and change load resistor to low range (X1) value, and RANGE switch to X1.
 - Adjust variable auto transformer for a 104Vac input.
 - Turn on BPS/A and adjust VOLTAGE control clockwise for the maximum rated positive output voltage (low range), as indicated on DVM.
 - Adjust variable auto transformer for a 127Vac input.
 - Reading on DVM should not vary from reading in step (o) by more than .4mV.
 - Set variable auto transformer for a 104Vac input.
 - Adjust VOLTAGE control counterclockwise for maximum rated negative low range output voltage, as indicated on DVM.
 - Adjust variable auto transformer for a 127Vac input.
 - Reading on DVM should not vary from reading in step (s) by more than .4mV.

5-13 **Load Effect (Load Regulation).**

Definition: The change ΔE_{OUT} in the

static value of dc output voltage resulting from a change in load resistance from open circuit to a value which yields maximum rated output current (or vice versa).

NOTE

The CURRENT MODE light should be off during this test.

- 5-14 The load regulation check is performed at low line conditions. To check load regulation, proceed as follows:
- Connect the test setup shown in Figure 5-1. Use the high range (X4) load resistance value.
 - Connect variable auto transformer between the input power source and the BPS/A power input. Adjust variable auto transformer for a 104Vac input.
 - Set BPS/A front panel controls as follows:

MODE switch:	POWER SUPPLY
RANGE switch:	X4
VOLTAGE control:	midposition
CURRENT control:	fully clockwise
VOLTAGE METER:	high range DC
CURRENT METER:	high range DC
 - Connect a DVM to the -S and +S terminals of the BPS/A.
 - Turn on BPS/A and adjust VOLTAGE control clockwise for the maximum rated positive output voltage as indicated on DVM.
 - Disconnect load resistor. Reading on DVM should not vary from the reading in step (e) by more than 2.5mV.
 - Adjust VOLTAGE control counterclockwise for maximum rated negative output (high range), as indicated on DVM.
 - Connect load resistor (high range value). Reading on DVM should not vary from reading in step (g) by more than 2.5mV.
 - Turn off BPS/A and change load resistor to low range (X1) value and RANGE switch to X1.
 - Turn on BPS/A and adjust VOLTAGE control clockwise for the maximum rated positive output voltage (low range), as indicated on DVM.
 - Disconnect load resistor. Reading on DVM should not vary from the reading in step (j) by more than 0.25mV.
 - Adjust VOLTAGE control counterclockwise for the maximum rated negative output voltage (low range), as indicated on DVM.
 - Connect load resistor (low range value). Reading on DVM should not vary from reading in step (e) by more than 0.25mV.

5-15 PARD (Ripple and Noise).

Definition: The residual AC voltage which is superimposed on the DC output of a regulated power supply. Ripple and noise may be specified and measured in terms of its RMS or (preferably) peak-to-peak value.

5-16 Ripple and noise measurement can be made at any input AC line voltage combined with any DC output voltage and load current within rating.

5-17 The amount of ripple and noise that is present on the power supply output is measured either in terms of the RMS or (preferably) peak-to-peak value. The peak-to-peak measurement is particularly important for applications where noise spikes could be detrimental to a sensitive load, such as logic circuitry. The RMS measurement is not an ideal representation of the noise, since fairly high output noise spikes of short duration could be present in the ripple and not appreciably increase the RMS value.

5-18 The technique used to measure high frequency noise or "spikes" on the output of a power supply is more critical than the low frequency ripple and noise measurement technique; therefore the former is discussed separately in Paragraph 5-26.

5-19 Ripple and Noise Measurements. Figure 5-2A shows an incorrect method of measuring p-p ripple. Note that a continuous ground loop exists from the third wire of the input power cord of the supply to the third wire of the input power cord of the oscilloscope via the grounded power supply case, the wire between the negative output terminal of the power supply, and the vertical input of the scope, and the grounded scope case. Any ground current circulating in this loop as a result of the difference in potential E_G between the two ground points causes an IR drop which is in series with the scope input. This IR drop, normally having a 60Hz line frequency fundamental, plus any pickup on the unshielded leads interconnecting the power supply and scope, appears on the face of the CRT. The magnitude of this resulting noise signal can easily be much greater than the true ripple developed between the plus and minus output terminals of the power supply, and can completely invalidate the measurement.

5-20 The same ground current and pickup problems can exist if an RMS voltmeter is substituted in place of the oscilloscope in Figure 5-2. However, the oscilloscope display, unlike the true RMS meter reading, tells the observer immediately whether the fundamental period of the signal displayed is 8.3 milliseconds (1/120Hz) or 16.7 milliseconds (1/60Hz). Since the fundamental ripple frequency present on the output of an HP supply is 120Hz (due to full-wave

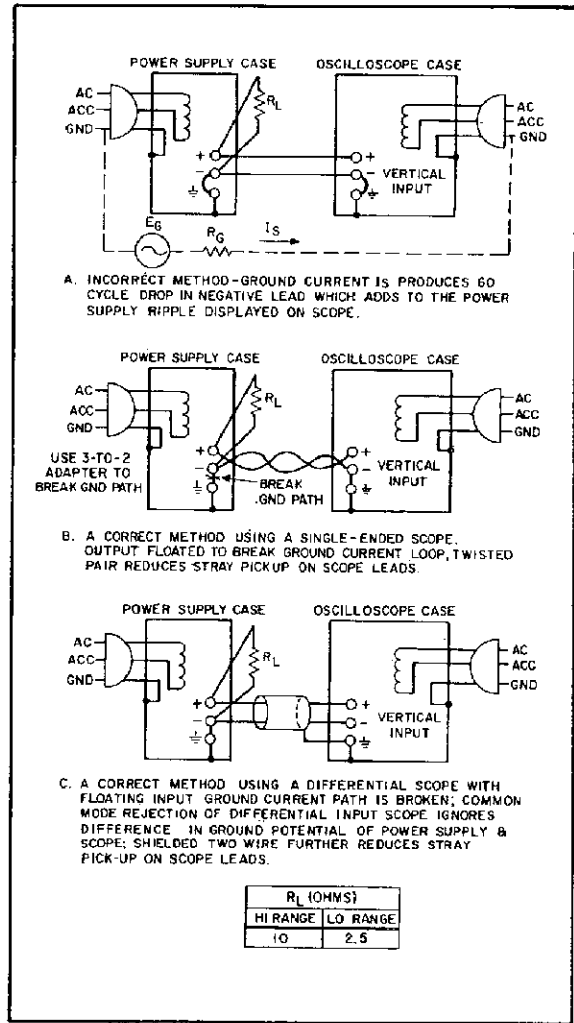

Figure 5-2. Ripple and Noise, Test Setup

rectification), an oscilloscope display showing a 120Hz fundamental component is indicative of a "clean" measurement setup, while the presence of a 60Hz fundamental usually means that an improved setup will result in a more accurate (and lower) value of measured ripple.

5-21 Figure 5-2B shows a correct method of measuring the output ripple of a constant voltage power supply using a single-ended scope. The ground loop path is broken by floating the power supply. Note that to ensure that no potential difference exists between the supply and the oscilloscope it is recommended that whenever possible they both be plugged into the same ac power buss. If the same buss cannot be used, both ac grounds must be at earth ground potential.

5-22 Either a twisted pair or (preferably) a shielded two-wire cable should be used to connect the output terminals of the power supply to the vertical input terminals of the scope. When using a twisted pair, care must be taken that one of the two wires is connected to the grounded input terminal of the oscilloscope. When using shielded two-wire, it is essential for the shield to be connected to ground at one end only so that no ground current will flow through this shield, thus inducing a noise signal in the shielded leads.

5-23 To verify that the oscilloscope is not displaying ripple that is induced in the leads or picked up from the grounds, the (+) scope lead should be shorted to the (-) scope lead at the power supply terminals. The ripple value obtained when the leads are shorted should be subtracted from the actual ripple measurement.

5-24 In most cases, the single-ended scope method of Figure 5-2B will be adequate to eliminate non-real components of ripple and noise so that a satisfactory measurement may be obtained. However, in more stubborn cases it may be necessary to use a differential scope with floating input as shown in Figure 5-2C. If desired, two single conductor shielded cables may be substituted in place of the shielded two-wire cable with equal success. Because of its common mode rejection, a differential oscilloscope displays only the difference in signal between its two vertical input terminals, thus ignoring the effects of any common mode signal introduced because of the difference in the ac potential between the power supply case and scope case. Before using a differential input scope in this manner, however, it is imperative that the common mode rejection capability of the scope be verified by shorting together its two input leads at the power supply and observing the trace on the CRT. If this trace is not a straight line, then the scope is not rejecting the ground signal and must be realigned in accordance with the manufacturer's instructions until proper common mode rejection is attained.

5-25 To check the ripple and noise output, proceed as follows:

- Connect the oscilloscope or RMS voltmeter as shown in Figures 5-2B or 5-2C. Set MODE switch to POWER SUPPLY. Turn CURRENT control fully clockwise.
- Adjust VOLTAGE control in the X1 and X4 ranges until front panel meter indicates maximum rated output voltage. Check both maximum rated positive and negative output voltages.
- The observed ripple and noise should be less than:

<u>X1 Range</u>	<u>X4 Range</u>
1.5mVrms/4mVp-p	5mVrms/15mVp-p

5-26 Noise Spike Measurement. When a high frequency spike measurement is being made, an instrument of sufficient bandwidth must be used; an oscilloscope with a bandwidth of 20MHz or more is adequate. Measuring noise with an instrument that has insufficient bandwidth may conceal high frequency spikes detrimental to the load.

5-27 The test setups illustrated in Figures 5-2A and 5-2B are generally not acceptable for measuring spikes; a differential oscilloscope is necessary. Furthermore, the measurement concept of Figure 5-2C must be modified if accurate spike measurement is to be achieved:

- As shown in Figure 5-3, two coax cables, must be substituted for the shielded two-wire cable.
- Impedance matching resistors must be included to eliminate standing waves and cable ringing, and the capacitors must be connected to block the DC current path.
- The length of the test leads outside the coax is critical and must be kept as short as possible; the blocking capacitor and the impedance matching resistor should be connected directly from the inner conductor of the cable to the power supply terminals.
- Notice that the shields of the power supply end of the two coax cables are not connected to the power supply ground, since such a connection would give rise to a ground current path through the coax shield, resulting in an erroneous measurement.
- Since the impedance matching resistors constitute a 2-to-1 attenuator, the noise spikes observed on the oscilloscope should be less than:

<u>X1 Range</u>	<u>X4 Range</u>
2mVp-p instead of 4mVp-p	7.5mVp-p instead of 15mVp-p

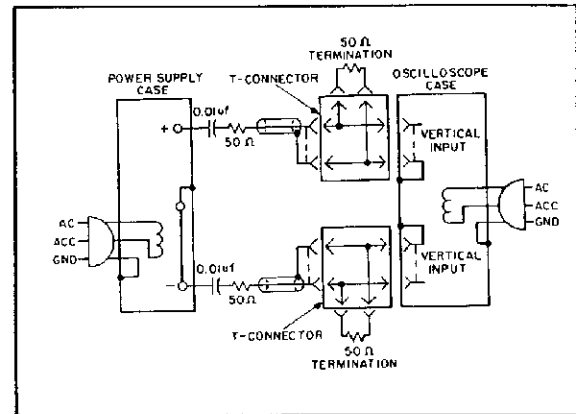

Figure 5-3. CV Noise Spike Test Setup

5-28 Transient Recovery Time.

Definition: The time "X" for the output voltage recovery to within "Y" millivolts of the nominal output voltage following a "Z" amp step change in load current, where: "Y" is specified as 20mV, the nominal output voltage is defined as the dc level between the static output voltage before and after the imposed load change, and "Z" is the specified load current change of the full load current rating of the supply.

5-29 Transient recovery time may be measured at any input line voltage combined with any output voltage and load current within rating.

5-30 Reasonable care must be taken in switching the load resistance on and off. A hand-operated switch in series with the load is not adequate, since the resulting one-shot displays are difficult to observe on most oscilloscopes, and the arc energy occurring during switching action completely masks the display with a noise burst.

5-31 A mercury-wetted relay, as connected in the load switching circuit of Figure 5-4 should be used for loading and unloading the supply. When this load switch is connected to a 60Hz ac input, the mercury-wetted relay will open and close 60 times per second. Adjustment of the 25K control permits adjustment of the duty cycle of the load current switching and reduction in jitter of the oscilloscope display.

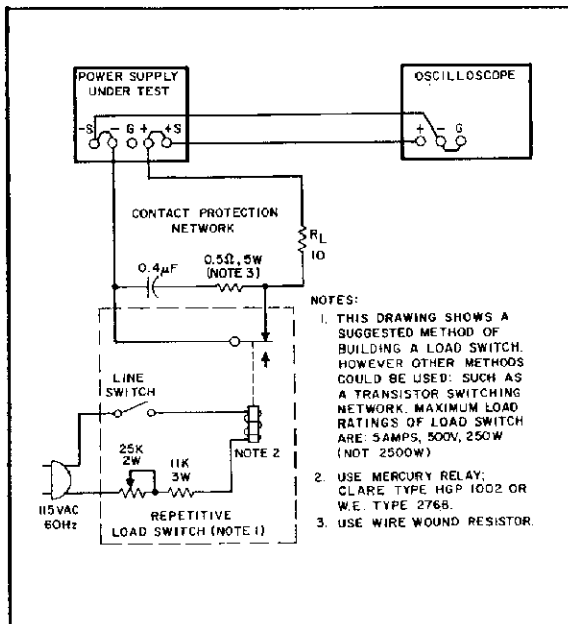

Figure 5-4. Transient Recovery Time Test Setup

5-32 To check the transient recovery time, proceed as follows:

- Connect test setup shown in Figure 5-4. Set MODE switch to POWER SUPPLY and RANGE switch to X4.
- Turn CURRENT control fully clockwise.
- Turn on supply and adjust VOLTAGE control clockwise until front panel ammeter indicates maximum positive rated output current.
- Close line switch on repetitive load switch set-up.
- Set oscilloscope for internal sync and lock on either positive or negative load transient spike.
- Set vertical input of oscilloscope for ac coupling so that small dc level changes in power supply output voltage will not cause display to shift.
- Adjust the vertical centering on the scope so that the tail ends of the no load and full load waveforms are symmetrically displayed about the horizontal center line of the oscilloscope. This center line now represents the nominal output voltage defined in the specification.
- Adjust the horizontal positioning control so that the trace starts at a point coincident with a major graticule division. This point is then representative of time zero.
- Increase the sweep rate so that a single transient spike can be examined in detail.
- Adjust the sync controls separately for the positive and negative going transients so that not only the recovery waveshape but also as much as possible of the rise time of the transient is displayed.
- Starting from the major graticule division representative of time zero, count to the right 100µsec and vertically 20mV. Recovery should be within these tolerances as illustrated in Figure 5-5.

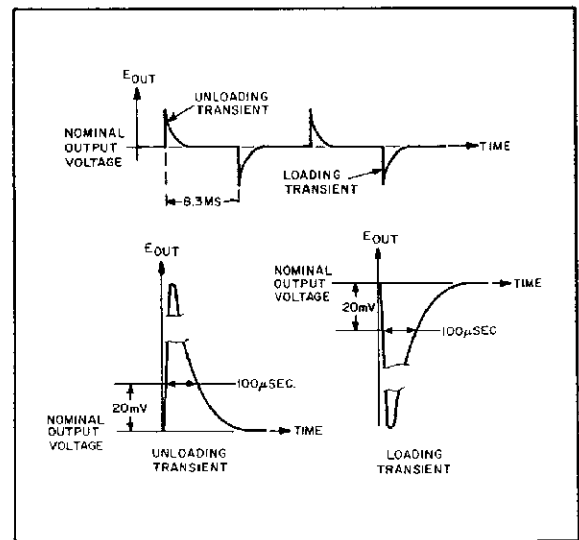

Figure 5-5. Transient Recovery Time, Waveforms

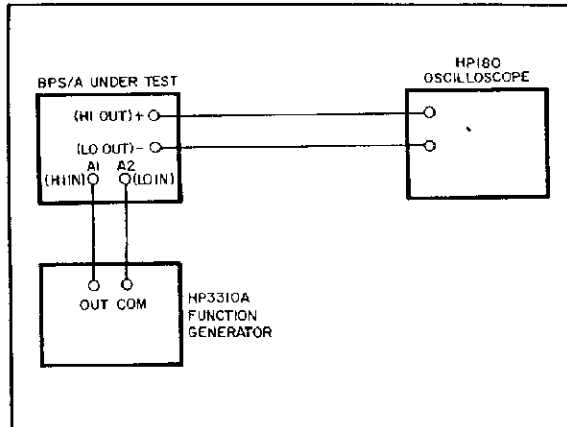

Figure 5-6. Programming Speed, Test Setup

5-33 Programming Speed. To check the unit's programming speed, a square wave is applied to the unit and it is operated in the amplifier mode. This has the same effect as rapidly programming the unit, up and down, in the power supply mode. To make this test, proceed as follows:

- Connect test setup as shown in Figure 5-6.
- Set MODE switch to VAR GAIN AMPL, RANGE switch to X4, and turn unit on.
- Rotate VOLTAGE control fully clockwise.
- On function generator, set input frequency to about 100Hz squarewave and adjust amplitude to obtain maximum rated peak-to-peak output signal on oscilloscope (-20V to +20V).
- Adjust oscilloscope to observe rise time of one squarewave. The waveshape should be within the tolerances shown on Figure 5-7 (output should change from maximum rated negative value to maximum rated positive value in less than 50μsec).
- Check the fall time of one squarewave. It should be almost identical to the rise time except for inversion.

5-34 Output Impedance. To check the output impedance, proceed as follows:

- Connect test setup as shown in Figure 5-8.
- Set MODE switch to POWER SUPPLY, RANGE switch to X4, and turn unit on.
- Adjust VOLTAGE control until front panel meter reads +20V.
- Set AMPLITUDE control on Oscillator to 10 volts (E_{in}), and FREQUENCY control to 100Hz sinewave.
- Record voltage across output terminals of the power supply (E_o) as indicated on AC voltmeter.
- Calculate the output impedance by the following formula:

$$Z_{out} = \frac{E_o R}{E_{in} - E_o}$$

- E_o = rms voltage across power supply output terminals.
 $R = 1000$
 $E_{in} = 10$ volts
 g. The output impedance should be less than .5 milliohm.

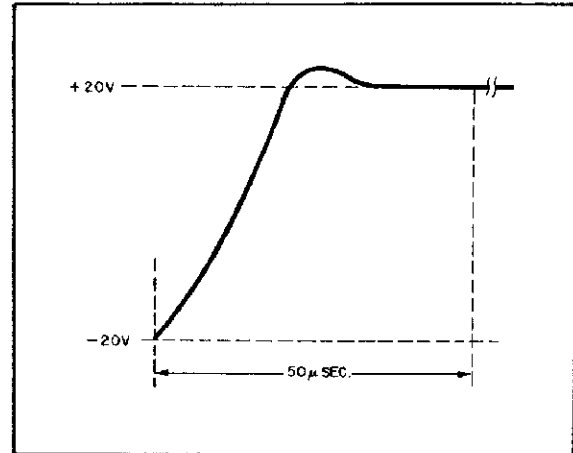

Figure 5-7. Typical Programming Speed Waveforms

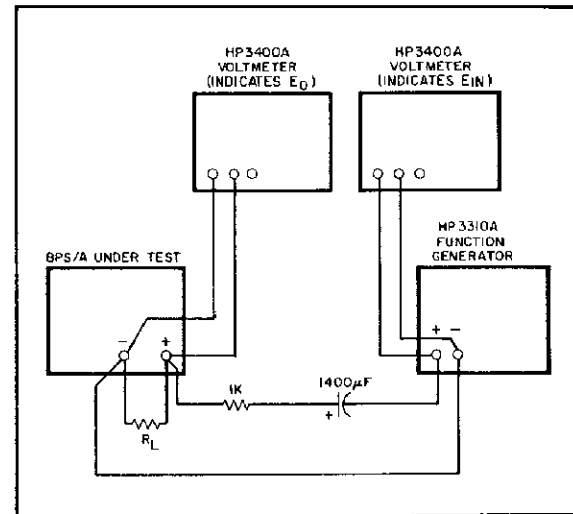

Figure 5-8. Output Impedance, Test Setup

5-35 Temperature Coefficient.

Definition: The change in output voltage per degree Centigrade change in the ambient temperature under conditions of constant input ac line voltage, output voltage setting, and load resistance.

5-36 The temperature coefficient of a power supply is measured by placing the power supply in an oven and varying it over any temperature span within its rating. (Most HP power supplies are rated for operation from 0°C to 55°C.) The power supply must be allowed to thermally stabilize for a sufficient period of time at each measurement temperature.

5-37 The temperature coefficient given in the specifications is the maximum temperature-dependent output voltage change which will result over any one degree Centigrade interval. The differential voltmeter or digital voltmeter used to measure the output voltage change of the supply should be placed outside the oven and should have a long term stability adequate to insure that its drift will not affect the overall measurement accuracy.

5-38 To check the temperature coefficient, proceed as follows:

a. Connect load resistance (high range) and differential voltmeter as illustrated in Figure 5-1.

NOTE

Connect voltmeter to $\pm S$ terminals, NOT across load.

b. Set MODE switch to POWER SUPPLY and RANGE switch to X4. Turn CURRENT control fully clockwise.

c. Adjust front panel VOLTAGE control until front panel voltmeter indicates maximum rated output voltage.

d. Place power supply in temperature-controlled oven (differential voltmeter and load remains outside oven). Set temperature to 30°C and allow 30 minutes for stabilization.

e. Record differential voltmeter reading.

f. Raise temperature to 40°C and allow 30 minutes for stabilization.

g. Observe differential voltmeter reading. Difference in voltage reading between step (e) and (g) should be less than 35mV.

h. Repeat steps (a) through (g) with low range (X1) load resistance connected as shown in Figure 5-1. Set RANGE switch to X1.

i. Observe differential voltmeter readings. Difference in voltage reading between step (e) and (g) should be less than 8.5mV.

5-39 Drift (Output Stability).

Definition: The change in output voltage for the first eight hours following a 30-minute warm-up period. During the interval of measurement all parameters, such

as load resistance, ambient temperature, and input line voltage are held constant.

5-40 This measurement is made by monitoring the output of the power supply on a differential voltmeter or digital voltmeter over the stated measurement interval; a strip chart recorder can be used to provide a permanent record. A thermometer should be placed near the supply to verify that the ambient temperature remains constant during the period of measurement. The supply should be put in a location immune from stray air currents (open doors or windows, air conditioning vents); if possible, the supply should be placed in an oven which is held at a constant temperature. Care must be taken that the measuring instrument has a stability over the eight hour interval which is at least an order of magnitude better than the stability specification of the power supply being measured. The supply will drift considerably less over the eight hour measurement interval than during the half-hour warm-up.

5-41 To check the output stability, proceed as follows:

a. Connect load resistance (high range) and differential voltmeter as illustrated in Figure 5-1.

b. Set MODE switch to POWER SUPPLY and RANGE switch to X4. Turn CURRENT control fully clockwise.

c. Adjust front panel VOLTAGE control clockwise until differential voltmeter indicates maximum rated output voltage.

d. Allow 30 minutes warm-up, then record differential voltmeter reading.

e. After 8 hours, differential voltmeter should change from reading recorded in step (d) by less than 11mV (pot wiper jump effect may add 20mV).

f. Repeat steps (a) through (e) with low range (X1) load resistance connected as shown in Figure 5-1. Set RANGE switch to X1.

g. Observe differential voltmeter reading. Difference in voltage reading between step (d) and (e) should be less than 2.5mV (pot wiper jump effect may add 5mV).

NOTE

If remote programming is employed, the potentiometer wiper jumper effect is eliminated.

5-42 CONSTANT CURRENT TESTS

5-43 The instruments, methods, and precautions for the proper measurement of constant current power supply characteristics are for the most part identical to those already

described for the measurement of constant voltage power supplies. There are, however, two main differences: First, the power supply performance will be checked between short circuit and full load rather than open circuit and full load. Second, a current monitoring resistor is inserted between the output of the power supply and the load.

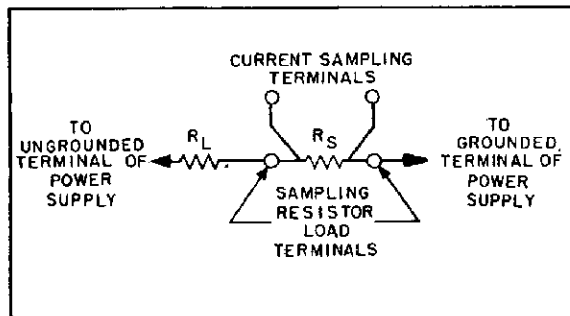

Figure 5-9. Current Sampling Resistor Connections

5-44 For all output current measurements the current sampling resistor must be treated as a four terminal device. In the manner of a meter shunt, the load current is fed to the extremes of the wire leading to the resistor while the sampling terminals are located as close as possible to the resistance portion itself (see Figure 5-9). Generally, any current sampling resistor should be of the low noise, low temperature coefficient (less than 20ppm/°C) type and should be used at no more than 10% of its rated power so that its temperature rise will be minimized.

NOTE

The CURRENT MODE light should be on during these tests.

5-45 Rated Output and Meter Accuracy.

- Connect test setup shown in Figure 5-10. Use high range load resistor (R_L) connected in series with the 1Ω resistor (R_S).
- Set BPS/A front panel controls as follows:

MODE switch:	POWER SUPPLY
RANGE switch:	X4
VOLTAGE control:	fully clockwise
CURRENT control:	fully counterclockwise
VOLTAGE METER:	high range DC
CURRENT METER:	high range DC
- Turn on BPS/A and adjust CURRENT control until front panel ammeter indicates maximum rated positive output current.
 - DVM should read +2.0V.
 - Turn VOLTAGE control fully counterclockwise and adjust CURRENT control until front panel am-

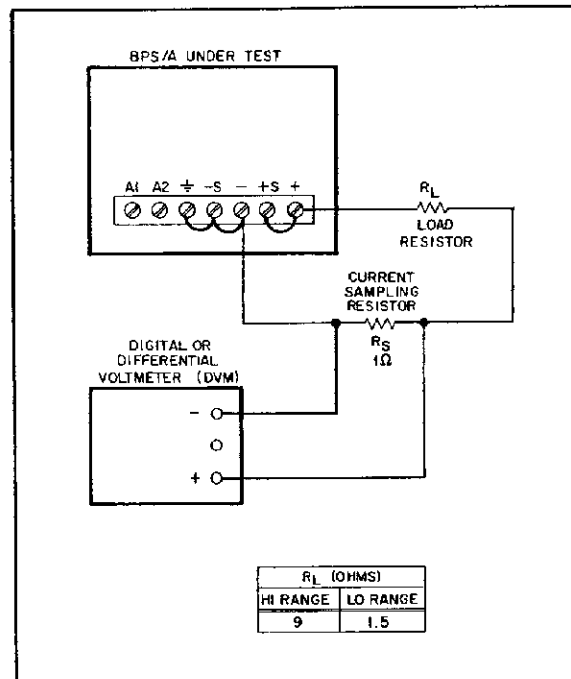

Figure 5-10. Constant Current, Test Setup

- meter indicates maximum rated negative output current.
- DVM should read -2.0V.

5-46 Source Effect (Line Regulation).

Definition: The change ΔI_{OUT} in the static value of dc output current resulting from a change in ac input voltage over the specified range from low line (usually 104 volts) to high line (usually 127 volts), or from high line to low line.

To check the line regulation, proceed as follows:

- Utilize test setup and front panel settings of Paragraph 5-45.
- Connect variable auto transformer between input power source and power supply power input.
- Adjust auto transformer for 104Vac input.
- Turn VOLTAGE control fully clockwise.
- Adjust CURRENT control until front panel ammeter reads exactly maximum rated positive output current.
- Read and record voltage indicated on differential voltmeter.
- Adjust variable auto transformer for 127Vac input.
- Reading on differential voltmeter should not vary from reading recorded in step (f) by more than $\pm 450\mu V$.

i. Turn VOLTAGE control fully counterclockwise and repeat steps (e) through (h) for negative output current.

5-47 Load Effect (Load Regulation).

Definition: The change ΔI_{OUT} in the static value of the dc output current resulting from a change in load resistance from short circuit to a value which yields maximum rated output voltage.

5-48 To check the constant current load regulation, proceed as follows:

- Utilize test setup and front panel settings of Paragraph 5-45.
- Turn VOLTAGE control fully clockwise.
- Adjust CURRENT control until front panel meter reads exactly maximum rated positive output voltage.
- Read and record voltage indicated on differential voltmeter.
- Short circuit load resistor (R_L).
- Reading on differential voltmeter should not vary from reading recorded in step (d) by more than $\pm 450\mu V$.
- Turn VOLTAGE control fully counterclockwise and repeat steps (c) through (f) for negative output voltage.

5-49 Ripple and Noise.

Definition: The residual ac current which is superimposed on the dc output current of a regulated power supply. Ripple and noise may be specified and measured in terms of its RMS or (preferably) peak-to-peak value.

5-50 Most of the instructions pertaining to the ground loop and pickup problems associated with constant voltage ripple and noise measurements also apply to the measurement of constant current ripple and noise. Figures 5-11 and 5-12 illustrate the most important precautions to be observed when measuring the ripple and noise of a constant current supply. The presence of a 120Hz waveform on the oscilloscope is normally indicative of a correct measurement method. A waveshape having 60Hz as its fundamental component is typically associated with an incorrect measurement setup.

5-51 Ripple Measurement. To check the output ripple, proceed as follows:

- Connect the oscilloscope as shown in Figures 5-11B or 511C.
- Rotate the VOLTAGE control fully cw.
- Set RANGE switch to X4, MODE switch to POWER SUPPLY and turn on BPS/A.

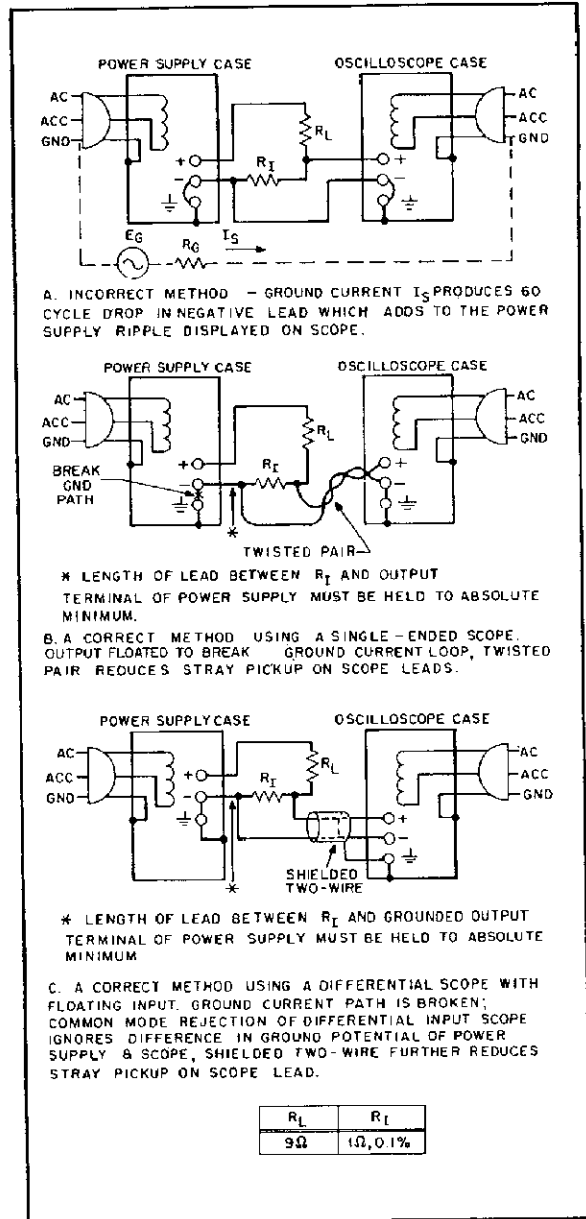

Figure 5-11. CC Ripple and Noise Test Setup

- Adjust CURRENT control until front panel meter reads exactly the maximum rated positive output current.
- The observed ripple should be less than 10mV p-p.
- Turn VOLTAGE control fully counterclockwise and repeat steps (d) and (e) for maximum rated negative output current.

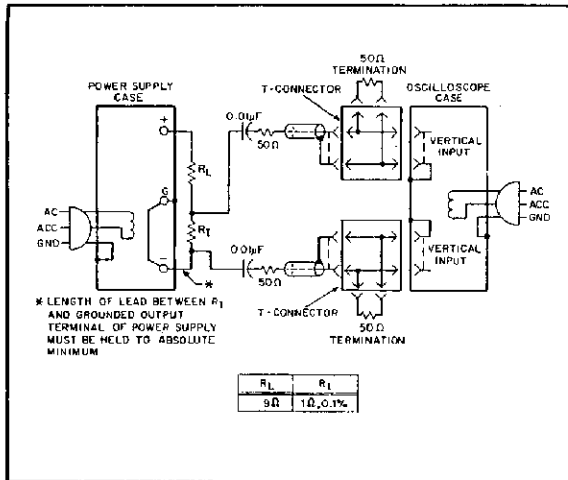

Figure 5-12. Constant Current Noise Spike Test Setup

5-52 Noise Spike Measurement. To check the noise spike output, proceed as follows:

- Connect test setup shown in Figure 5-12.
- Turn VOLTAGE control fully clockwise.
- Set RANGE switch to X4, MODE switch to POWER SUPPLY, and turn on BPS/A.
- Adjust CURRENT control until front panel ammeter indicates the exact maximum rated positive output current.
- Since the impedance matching resistors constitute a 2:1 divider, the observed noise spikes should be less than 5mV p-p.

5-53 Current Sink Test. The current sink test is performed using two BPS/A's. One is used as a test instrument and the other is used as a source instrument. Two identical BPS/A's are preferred to perform this test.

CAUTION

If two BPS/A's of the same model are not available, this test can be performed utilizing any other Bipolar supply. However, it is of the utmost importance that the BPS/A output voltage be set below the other supply so that it will sink rather than force the other supply to sink which it may not be capable of doing.

To check the current sink performance of the BPS/A, proceed as follows:

- On the test instrument, set controls as follows:
 MODE switch: POWER SUPPLY
 RANGE switch: X4
 VOLTAGE control: fully clockwise
 CURRENT control: fully clockwise

b. On the source instrument, set controls as follows:

MODE switch: FXD GAIN AMP
 RANGE switch: X4

c. Turn on test instrument and set output to +20V.

d. Connect function generator to terminals A1 and A2 of source instrument. Turn on and adjust source instrument output to 40V p-p at 100Hz (approximately).

e. Turn off test and source instruments and connect test setup of Figure 5-13.

f. Turn on both instruments simultaneously and observe that waveform sampled across the 1 ohm resistor is as illustrated in Figure 5-14.

g. Repeat test with VOLTAGE control on test instrument set fully counterclockwise. Waveform should be same as Figure 5-14.

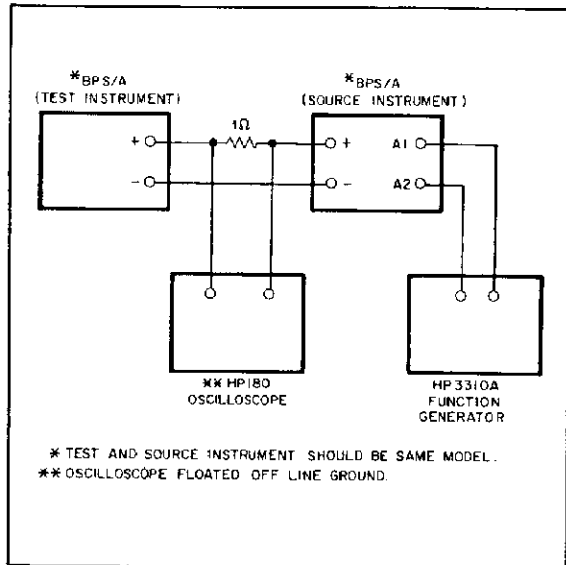

Figure 5-13. Current Sink Test Setup

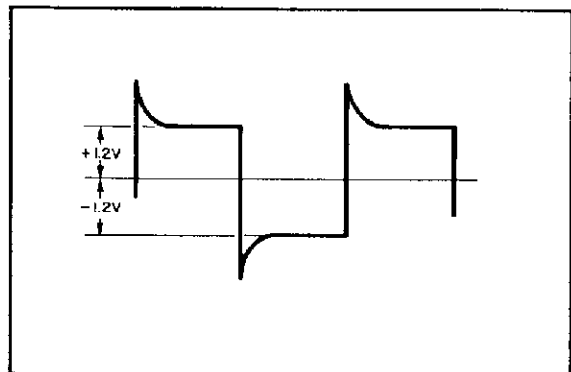

Figure 5-14. Current Sink Test Waveform

5-54 Overcurrent Protection Test. To check the overcurrent protect circuit, proceed as follows:

- a. Set BPS/A front panel controls as follows:
 MODE switch: FXD GAIN AMP
 RANGE switch: X4
 VOLTAGE control: fully clockwise
 CURRENT control: fully clockwise
- b. Apply a 5V p-p, 100Hz squarewave to the A1 (HI IN) and A2 (LO IN) terminals.
- c. Connect a 1Ω, 5W resistor across + (HI OUT) and - (LO OUT) terminals. Connect oscilloscope across 1Ω resistor.
- d. Turn on BPS/A and observe waveforms (see Figure 5-15). Overshoot should not exceed 5V p-p.

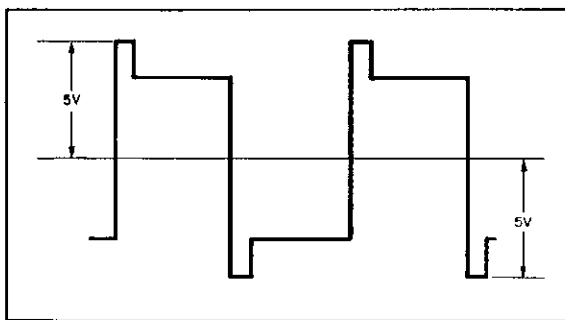

Figure 5-15. Overcurrent Protect Test Waveform

5-55 Turn-on/off Transient Protect. To test the turn-on/off transient protect circuit proceed as follows:

- a. Set front panel controls as follows:
 MODE switch: POWER SUPPLY
 RANGE switch: X4
 VOLTAGE control: fully clockwise
 CURRENT control: fully clockwise
- b. Connect a clip lead from base of A3Q1 to ground (2).
- c. Turn on BPS/A. Output should be from 0 to 1.5Vdc.
- d. Remove clip lead, output should be +20V.
- e. Repeat steps (a) through (d) except turn VOLTAGE control fully ccw for -20V output.

5-56 AMPLIFIER MODE TESTS

5-57 Gain and Meter Accuracy Test. To check gain and the meter accuracy in the amplifier modes, proceed as follows:

- a. Connect the test setup as shown in Figure 5-16. Use the appropriate low range load resistor (R_L).
- b. Set BPS/A front panel controls as follows:
 MODE switch: VAR GAIN AMP
 RANGE switch: X1

- VOLTAGE control: fully clockwise
- CURRENT control: fully clockwise
- VOLTAGE METER: low range AC
- CURRENT METER: high range AC
- c. Set generator frequency at 100Hz sinewave and output at 2V peak-to-peak.
- d. Turn on BPS/A and allow a five minute warm-up period.
- e. Connect oscilloscope to +S and -S terminals.
- f. Adjust VOLTAGE control to obtain a 4V p-p reading on the oscilloscope.
- g. Observe that front panel voltmeter reads 1.4V rms and the front panel ammeter reads .56A rms.
- h. Turn off BPS/A and connect appropriate high range load resistor. Set RANGE switch to X4 and VOLTAGE METER switch to high range AC. Increase generator output to 5V p-p.
- i. Turn on BPS/A and observe oscilloscope for a 40V p-p signal.
- j. Observe that front panel voltmeter reads 14V rms and front panel ammeter reads 1.4A rms.
- k. Set MODE switch to FXD GAIN AMP MODE and increase generator output to 10V p-p.
- l. Observe a 40V p-p signal on oscilloscope.

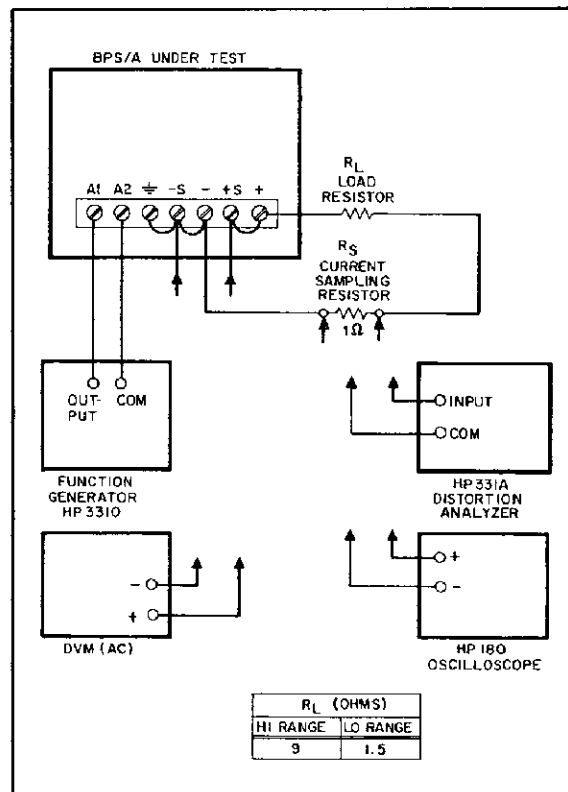

Figure 5-16. Amplifier Mode Test Setup

- 5-58 Frequency Response.** To check amplifier mode frequency response, proceed as follows:
- Connect the test setup as shown in Figure 5-16.
 - Set MODE switch to VAR GAIN AMP and set VOLTAGE and CURRENT controls fully clockwise.
 - Set HP3310A generator output at 100Hz sine-wave and adjust signal amplitude to provide 40V p-p output.
 - Adjust the generator frequency until output drops to 27V p-p. This frequency should not be less than 15kHz.
 - Set MODE switch to FXD GAIN AMP and repeat steps (c) and (d) above. Frequency should not be less than 35kHz.

- 5-59 Distortion Test.** To check the total harmonic distortion (THD) in the amplifier output, proceed as follows:
- Connect the test setup as shown in Figure 5-16.
 - Set MODE switch to VAR GAIN AMP.
 - Set generator at 100Hz sinewave and adjust output for full BPS/A output voltage and current with appropriate load.
 - Measure the distortion at the output using HP 331A Distortion Analyzer.
 - The THD should be less than .1%.

NOTE

The above is a difficult measurement because the THD is so low. Most audio generators will contain more than .1% THD in their output. A first order figure can be obtained by the following relationship:

$$\text{THD of Amplifier} = \sqrt{\frac{\text{THD of (gen.+amp)}^2 - \text{THD gen.}^2}{\text{THD of (gen.+amp)}^2}}$$

5-60 TROUBLESHOOTING

WARNING

The following troubleshooting procedures are performed with power applied to the BPS/A while its protective covers are removed. Be careful when performing the procedures as line voltage is always present on the power input connector, fuse holder, and in the power supply rectifier circuits. In addition, when the supply is on, energy available at many points, particularly the power transistors on the rear heat sink, may result in personal injury or death when contacted.

5-61 GENERAL

5-62 Before attempting to troubleshoot this instrument, ensure that the fault is with the instrument and not with an associated circuit. The performance test (Paragraph 5-5) enables this to be determined without removing the instrument's covers. A good understanding of the principles of operation is a helpful aid in troubleshooting, and it is recommended that the reader review Section IV of the manual before attempting to troubleshoot the instrument. Once the principles of operation are understood, refer to the trouble isolation procedures.

5-63 Figure 7-1 is a simplified schematic of the BPS/A and is useful in tracing signal flow through the entire instrument. Figure 7-2 (2 Sheets) is a detailed schematic of the unit. The circled test point numbers on Figure 7-2 are also marked on the component location diagrams which accompany the schematics. References are made to these test points in the troubleshooting procedures.

5-64 OVERALL TROUBLE ISOLATION PROCEDURE

5-65 Figure 5-17 illustrates the overall scheme of the trouble isolation and troubleshooting procedures which follow. The trouble isolation procedures represented by the boxes in the left-hand column are intended to localize a problem to a particular area, both by direct testing and a process of elimination. Instructions at each stage of the isolation procedure direct you to the appropriate troubleshooting instructions, if required. These steps must be followed in the order in which they are given so that circuits are operational that are needed for testing other circuits. It is not necessary to make any calibration adjustments until troubleshooting has been completed. At that time, any necessary adjustments should be made and then the performance test of Paragraph 5-5 should be completed.

CAUTION

Trouble isolation by swapping a good board for a suspected faulty one is not recommended unless it is certain that the fault is not destructive.

5-66 Preliminary Trouble Isolation Checks. Make the following checks for obvious troubles before continuing with the troubleshooting procedures.

- Check that the rear terminal strapping is correct for local or remote programming (see Section III).

CAUTION

The rear terminals must be strapped correctly before power is applied to the instrument.

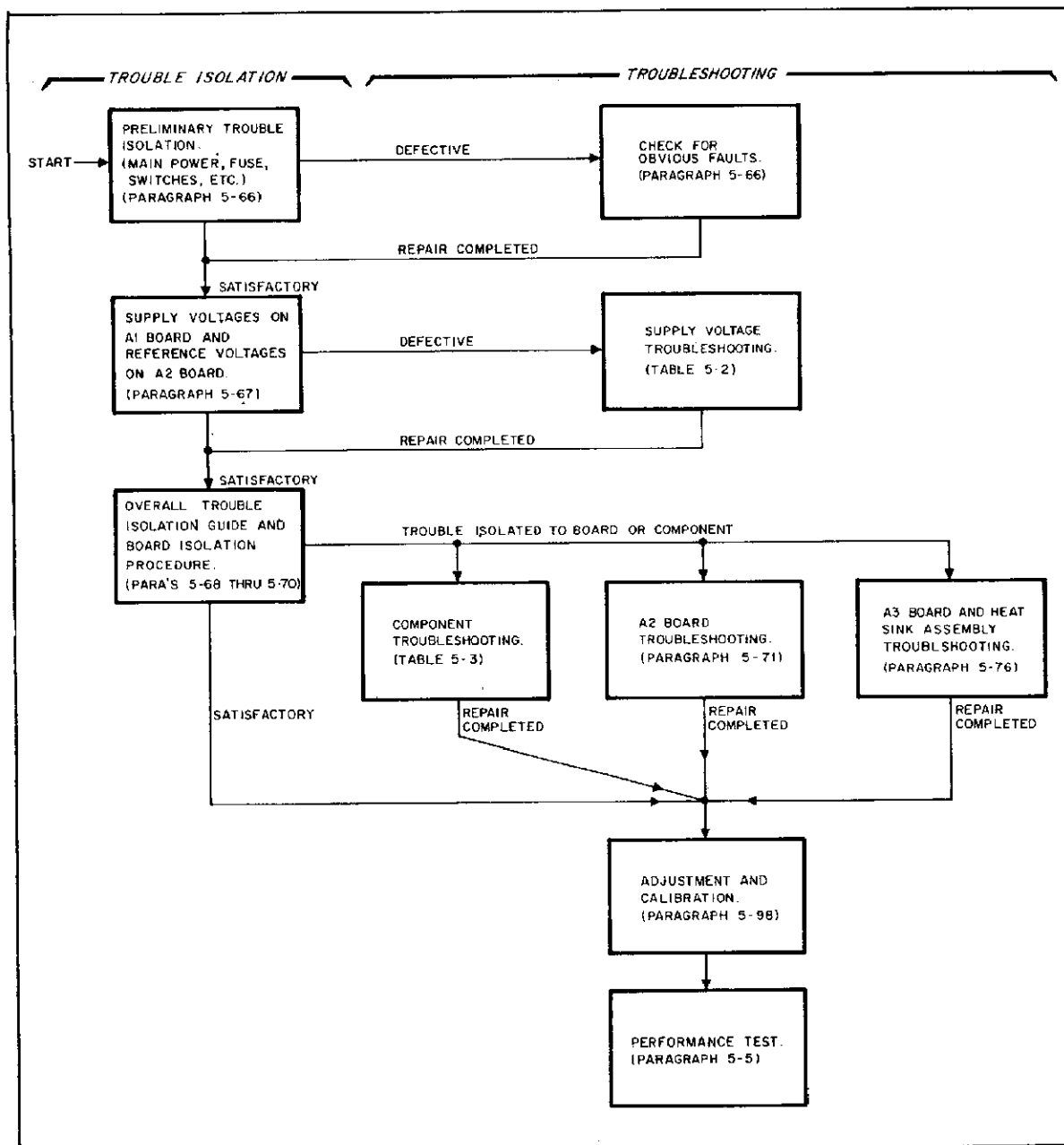

Figure 5-17. Trouble Isolation and Troubleshooting Procedure, Overall Scheme

2. Ensure that the MODE and RANGE switches are in the desired position.

3. Check the line fuse. If the line fuse is open, proceed as follows:

- a. Ensure that the proper ac input (115 or 230Vac) is selected (slide switch on power module) and install a fuse of

proper rating; 1A for 115Vac or 0.5A for 230Vac.

b. Check the following:

On chassis check for short circuits – Main power transformer T1 and filter capacitors C1, C2, and C3.

On board A1 check for short circuits — All filter capacitors and rectifier diodes. Also, check for shorts across power tracks on board.

On board A3 check for short or open circuits — A3C11, Q12-Q19 (shorted) A3CR14-CR17 (opened)

On heat sink assembly — Check output power transistors.

4. Check that the LOCAL/AUTO switch on board A2 is in the LOCAL position (see Figure 3-9). For normal operation of the BPS/A, this switch must be left in the LOCAL position. The AUTO position is used only for auto-series, auto-parallel operation (see Section III).

5. Check continuity of ribbon cables W1 and W2 from the A1 board to the heat sink assembly and rear terminal strips respectively.

6. Check for defective meter(s), power cord, and loosely connected circuit boards. Visually inspect circuit boards for mechanical damage and discolored or charred components.

7. If steps (1) through (6) have not isolated the trouble, check the supply voltages (Paragraph 5-67).

5-67 Supply Voltage Checks. In almost all cases, the trouble can be caused by an incorrect supply voltage (main, bias, or reference voltage); thus, it is a good practice to check these voltages (see Table 5-2). Although isolation of the trouble source to a particular board is desirable, possible trouble in one of the internal power sources should be investigated first. The tests described in Table 5-2 constitute a relatively fast check for trouble in this area. In many cases, these checks can save many hours of troubleshooting circuits which are actually operating properly. If the supply voltage checks have not isolated the trouble, proceed according to the overall trouble isolation guide (Paragraph 5-68).

NOTE

There are two separate supply voltage returns in the BPS/A designated ① and ② in addition to chassis ground \perp . When making voltage or waveform measurements, be sure to use the appropriate return. The DVM or oscilloscope used must have a floating input since the ① and ② returns are not at chassis ground.

Table 5-2. Main Supply, Bias Supply, and Reference Voltages

METER COMMON	METER POSITIVE	NORMAL READING	CHECK IF NOT CORRECT
<u>Main Supply Voltages</u>			
①	TP1	+35 ± 1.5Vdc	A1C7, C9, C10, CR12, CR13, R5
TP2	①	-35 ± 1.5Vdc	A1C11, C12, C15, CR14, CR15, R6
①	TP3	+45 ± 2Vdc	A1C5, C6, C8, CR10, CR11
TP4	①	-45 ± 2Vdc	A1C13, C14, C16, CR16, CR17
<u>Bias Supply Voltages</u>			
②	TP5	+15 ± .8Vdc	A1C3, C17, CR3, CR5, CR6, Q1, Q2, VR1
TP6	②	-15 ± .8Vdc	A1C4, C18, CR7, CR8, Q3, Q4, VR3
②	TP7	+20 ± 2Vdc (unfil)	A1CR1, CR2
②	TP8	+20 ± 2Vdc (fil)	A1CR5, CR6, C3
<u>Reference Voltages</u>			
-S	TP9	+6.2 ± .35Vdc	A2VR4
TP10	-S	-6.2 ± .35Vdc	A2VR3
-OUT	TP11	+6.2 ± .35Vdc	A2VR2
TP12	-OUT	-6.2 ± .35Vdc	A2VR1
NOTE: Test points 1 through 8 are shown on sheet 1 and test points 9 through 12 are shown on sheet 2 of schematic. (All voltages specified at nominal line.)			

5-68 Overall Trouble Isolation Guide. After checking the supply voltages, disconnect the load and examine Table 5-3. This table contains a list of symptoms and probable causes that may cut down on troubleshooting time. For each trouble symptom, Table 5-3 isolates the trouble to a component or group of components or directs the reader to additional procedures if further isolation of the trouble is necessary.

5-69 In general, if the BPS/A operates properly in the power supply mode, it should also operate properly in the amplifier mode (variable gain or fixed gain amplifier mode). The trouble symptoms listed in Table 5-3 isolate the trouble to defective components or groups of components (functional circuit areas). The voltage control stages on board A2 in conjunction with the output power amplifier stages on board A3 and the heat sink assembly provide the desired

output voltage/gain. The voltage control stages A2U1 and A2U2 are common to both positive and negative outputs. The bipolar amplifier circuits on board A3 and the bipolar series regulator/output amplifier stages on the heat sink assembly consist of positive and negative stages for positive and negative outputs respectively. The current control circuits consist of positive current comparison stage (A2U3) and negative current comparison stage (A2U4) and associated common circuits consisting of dual ganged CURRENT control A5R1, speedup network (A2Q1, C9), and current sampling resistor A2R27. The CURRENT MODE indicator A5DS2 lights and a FLAG indication is present (high level at terminal A17) when the BPS/A is in constant current operation. During constant current operation, stages A2Q5 or A2Q6 provide the proper level to control the CURRENT MODE lamp driver (A2Q2, Q3) and FLAG output driver (A2Q4) stages for positive or negative output current respectively.

Table 5-3. Overall Trouble Isolation Guide

SYMPTOM	PROBABLE CAUSE
No output voltage (All modes: POWER SUPPLY, VAR GAIN AMP, FXD GAIN AMP)	<ul style="list-style-type: none"> a. Fuse blown or incorrect rear terminal strip strapping, etc. (see Paragraph 5-66). b. Main, bias, or reference voltages defective (see Paragraph 5-67). c. Relay A1K1, circuit board (A2 or A3), or output power transistors on heat sink assembly defective (see Paragraph 5-70).
Zero or low output voltage (POWER SUPPLY mode only)	<ul style="list-style-type: none"> a. MODE switch defective b. Internal positive dc reference defective (A2C10, R3, R58, R59)
Zero or low output voltage (POWER SUPPLY and VAR GAIN AMP modes only).	<ul style="list-style-type: none"> a. Voltage reference/gain control amplifier stage A2U2 defective (see Paragraph 5-71). b. VOLTAGE control A5R2 defective.
No output (VAR GAIN AMP and FXD GAIN AMP modes only).	<ul style="list-style-type: none"> a. MODE switch not in proper position. b. Improper connections to rear terminals A1 and A2 or front panel terminals H1 IN and LO IN.
Output voltage correct in X4 range, but incorrect in X1 range or vice versa.	<ul style="list-style-type: none"> a. RANGE switch defective. b. Relays A2K2 and/or A2K3 defective.
Negative output normal but zero or low positive output.	<ul style="list-style-type: none"> a. Check the main positive supply voltages (see Table 5-2): +35V, +45V b. Positive turn on/off circuit defective (A2Q2 shorted). c. Defective positive output power transistor stage on heat sink assembly: Q1 or Q2 defective. d. Defective positive coupling amplifier or driver stages on A3 board: A3Q6, Q7, Q8 (opened), VR2 (shorted)
Output voltage latched to maximum positive.	<ul style="list-style-type: none"> a. Amplifier stage on A3 board defective, A3Q6 shorted. b. Positive current comparison amplifier output diode (A2CR14) shorted.

Table 5-3. Overall Trouble Isolation Guide (Continued)

SYMPTOM	PROBABLE CAUSE
Positive output normal, but zero or low negative output.	a. Check the main negative supply voltages (see Table 5-2): $-35V$, $-45V$. b. Negative turn on/off circuit defective (A2Q3 shorted). c. Defective negative output power transistor on heat sink assembly: Q3 or Q4 defective. d. Defective negative coupling amplifier or driver stages on A3 board: A3Q9, Q10, Q11 (opened), VR1 (shorted)
Output voltage latched to maximum negative.	a. Amplifier stage on A3 board defective. A3Q11 shorted. b. Negative current comparison amplifier output diode (A2CR13) shorted.
No constant current operation.	a. Check reference voltages at TP11 and TP12 and bias voltages at TP5 and TP6 (see Table 5-2). b. Check circuit components common to positive (A2U3) and negative (A2U4) comparison amplifiers: Dual ganged CURRENT control — A5R2 Speed up network — A2C9, Q1, R27, R46, R47
No positive constant current operation (negative constant current circuits operate properly).	a. Check positive reference voltage at TP11 (see Table 5-2). b. Positive current comparison amplifier A2U3 defective (see Paragraph 5-71). c. A2CR5, CR14, or VR5 defective.
No negative constant current operation (positive constant current circuits operate properly).	a. Check negative reference voltage at TP12 (see Table 5-2). b. Negative current comparison amplifier A2U4 defective (see Paragraph 5-71). c. A2CR13 or VR6 defective.
Positive constant current circuits operate properly but CURRENT MODE indicator does not light.	PNP switch A2Q5 opened.
Negative constant current circuits operate properly but CURRENT MODE indicator does not light.	NPN switch A2Q6 opened.
CURRENT MODE indicator always on (FLAG output low).	Defective lamp driver circuit: A2Q2 opened or A2Q3 shorted.
FLAG output (terminal A17) always high (about +16V).	FLAG driver A2Q4 opened.
CURRENT MODE indicator always on and FLAG output always high.	Diode A2CR10 opened.
Constant current circuits operate normally but CURRENT MODE indicator does not light.	a. Indicator (LED) A5DS2 defective. b. Defective lamp driver circuit: A2Q2 shorted or A2Q3 opened.

Table 5-3. Overall Trouble Isolation Guide (Continued)

SYMPTOM	PROBABLE CAUSE
Constant current circuits operate normally but no FLAG output (always low).	a. FLAG driver A2Q4 shorted. b. Jumper A2W1 not installed.
Positive current sink inoperative.	A2CR3, CR11, CR12 or R28 defective.
Negative current sink inoperative.	A2CR4, CR7, CR8 or R29 defective.
Bandwidth too narrow in VAR GAIN AMP mode.	A2U1 defective.

5-70 Board Isolation Procedure. The board isolation procedure describes how to isolate trouble to the turn on/off circuit on boards A1 and A3, the voltage/current control circuits on board A2, or to the output power amplifier stages on board A3 and the heat sink assembly. The board isolation procedures assumes that an output problem exists in all three modes of operation and all trouble isolation procedures up to this point have been completed. To isolate the trouble to the defective board(s), proceed as follows:

WARNING

The following troubleshooting procedures are performed with power applied to the BPS/A while its protective covers are removed. Be careful when performing the procedures as line voltage is always present on the power input connector, fuse holder, and in the power supply rectifier circuits. In addition, when the supply is on, energy available at many points, particularly the power transistors on the rear heat sink, may result in personal injury or death when contacted.

- a. Remove covers and A3 board from the instrument.
- b. Remove load and connect a DVM to the +S and -S rear terminals.
- c. Set controls on front panel as follows:
 - MODE switch: POWER SUPPLY
 - RANGE switch: X4
 - VOLTAGE control: fully clockwise
 - CURRENT control: fully clockwise

- VOLTAGE METER: high range DC
- CURRENT METER: high range DC
- d. Turn on power and observe that LINE indicator lights.
- e. Check that turn on/off relay A1K1 is operating properly by connecting ohmmeter between A1K1 pin 1 and ②. Ohmmeter should indicate an open circuit. If a short circuit (zero ohms) is present, check relay A1K1 and associated components (A1C2, CR4, R32, R37). If open circuit is present, proceed to step (f).
- f. Turn off power and isolate the turn on/off circuit on board A3 by lifting the connections from diodes A3CR3 and A3CR4 to the collectors of transistors A3Q2 and A3Q3 respectively. Install A3 board in instrument.
- g. Turn on power. If output voltage is normal (max. positive), the turn on/off circuit (A3Q1-A3Q5) is defective. If output is zero or low, proceed to step (h).
- h. Turn off power and reconnect diodes A3CR3 and A3CR4. Connect -5Vdc to the A1 (H1 IN) and A2 (LO IN) terminals.
- i. Set MODE switch to FXD GAIN AMP position and turn on power. If output voltage is normal (max. positive), the voltage/gain reference stage A2U2 is probably defective (see Paragraph 5-71). If output is zero, proceed to step (j).
- j. Turn power off. Remove the A2 board. Connect a variable dc voltage source (-2.5V to -4.5V) between A3 pin 5 and ②. Connect negative potential to A3 pin 5.
- k. Turn on power and vary the negative source voltage from -2.5V to -4.5V. Output voltage should vary accordingly from maximum positive to maximum negative value through zero. If output voltage is normal, the A2 board is defective (see Paragraph 5-71). If output is not normal, the A3 board or output power transistor stages on heat sink assembly are defective (see Paragraph 5-76).

5-71 A2 BOARD TROUBLESHOOTING

NOTE

For normal operation of the BPS/A, the Local/Auto switch A2S1 must be in the "Local" position (see Figure 3-9). The "Auto" position is used only for auto-series, auto-parallel, or auto-tracking operation (see Section III). If this switch is left in the "Auto" position for normal operation, the output will be latched at full positive or negative depending on other control settings.

5-72 The A2 plug-in board contains the voltage and current control circuits which can be separated functionally allowing the trouble to be isolated to the individual circuit level. The following paragraphs provide troubleshooting procedures for the voltage control, current control, and RMS current meter driver circuits located on board A2.

5-73 **Voltage Control Circuits.** Integrated circuit amplifiers A2U1 (voltage comparison amplifier) and A2U2 (voltage reference/gain control amplifier) with their circuit components are part of the constant voltage feedback loop. The following procedure consists of a series of fast checks to isolate trouble in these circuits.

- a. Remove top and right side covers from instrument. Remove the A3 board.
- b. Ensure that rear terminal strip is strapped correctly for local operation (see Section III).
- c. Set front panel controls as follows:

MODE switch:	POWER SUPPLY
RANGE switch:	X1
VOLTAGE control:	fully counterclockwise
CURRENT control:	fully clockwise
- d. Connect a DVM between A2U2 pin 6 (TP14) and -S.
- e. Turn VOLTAGE control through its range and observe that DVM reading varies from 0 to -10V. If voltage reading is correct, proceed to step (f). If the output at pin 6 is $\pm 15V$, check A2CR1, CR2, U2 for short circuits. If the output at pin 6 is zero, VOLTAGE control A5R2 is open or defective, or A2U2 is defective.
- f. Set VOLTAGE control for reading of -5V on DVM.
- g. Set MODE switch to VAR GAIN AMP positive and connect oscilloscope between A2U1 pin 6 (TP13) and -S.
- h. Apply a 100Hz sinewave (about 40mV p-p) to the HI IN (A1) and LO IN (A2) terminals. If A2U1 is operational, a sinewave (approximately 8V p-p) should be observed on oscilloscope. If there is no output, A2U1 or A2K1 is defective. If the output at A2U1 pin 6 is $\pm 15Vdc$, A2CR18, CR19, or A2U1 is shorted.

5-74 **Current Control Circuits.** Integrated circuit amplifiers A2U3 (positive current comparison amplifier) and A2U4 (negative current comparison amplifier) control constant current operation for positive and negative output currents respectively. An "OR" function results if either circuit is operational and control is established. To check these circuits proceed as follows:

- a. Remove top and right side covers from instrument. Remove the A3 board.
- b. Remove strap between terminals A13 and A14, and apply a small variable dc voltage (approximately $\pm 0.2Vdc$) between terminals A14 and A18.
- c. Connect a DVM between A2U3 pin 6 (TP16) and -S. Turn on power and note that DVM reads from approximately +7V to -8V as the source voltage is varied through zero. If voltage reading is correct, proceed to step (d). If reading is $\pm 15V$, check A2U3 for short. If reading is zero, A2U3 is defective.
- d. Turn power off and replace straps between terminals A13 and A14. Remove straps between terminals A20 and A21. Apply a small variable dc voltage (approximately $\pm 0.2Vdc$) between terminals A21 and A18.
- e. Connect a DVM between A2U4 pin 6 (TP17) and -S. Turn on power and note the DVM reads approximately +7V to -8V as the source voltage is varied through zero. If reading is not correct, the A2U4 stage is defective.

5-75 **RMS Current Meter Driver.** Integrated circuit A2U5 provides the gain necessary to drive diode detector A1CR18 which allows ac current to be metered through the detection process. To determine if A2U5 is operational, apply a sinewave (2V p-p, 100Hz) with a dc offset of -0.2Vdc to the -OUT side of A2C13. Observe that a sinewave of approximately 28-30V p-p is present at pin 6 of A2U5. Connect oscilloscope between A2U5 pin 6 and  for this measurement.

5-76 A3 BOARD AND HEAT SINK ASSEMBLY TROUBLESHOOTING

WARNING

The following troubleshooting procedures are performed with power applied to the BPS/A while its protective covers are removed. Be careful when performing the procedures as line voltage is always present on the power input connector, fuse holder, and in the power supply rectifier circuits. In addition, when the supply is on, energy available at many points, particularly the power transistors on the rear heat sink, may result in personal injury or death when contacted.

5-77 The A3 plug-in board contains positive and negative amplifier and driver stages which amplify the control voltage from board A2 in order to control the conduction of the output power transistors on the heat sink assembly. The A3 board and heat sink assembly stages can be isolated from the voltage and current feedback loops by removing the A2 board from the instrument and providing an external control voltage input to the A3 board. The following paragraphs describe troubleshooting procedures for the A3 board and heat sink assembly circuits.

5-78 Output Amplifier Stages. To troubleshoot the amplifier and driver stages on the A3 board and the output power transistors on the heat sink assembly, proceed as follows:

- a. Remove the A2 board from the unit and remove the load from the output terminals.
- b. Connect function generator (HP3310A) output terminals between the connector side of A3R15 and . Set output of function generator for a sinewave of approximately 2V p-p at 100Hz with a dc offset of -3.5V. Connect an oscilloscope to +S and -S terminals.
- c. Turn on power and observe a sinewave output of 40V p-p. The sinewave should not be clipped or distorted.
- d. If either polarity of the sinewave is missing or distorted, troubleshoot by tracing the sinewave back to the source. Refer to Figure 7-2 (Sheet 1). Also, check the turn on/off circuit (Paragraph 5-79).

NOTE

When troubleshooting the power amplifier circuits, keep in mind that possible trouble areas exist in the interconnections (A1 board, W1, and W2 ribbon cables) as well as the A3 board circuits and the output power transistors Q1-Q4 on the heat sink assembly.

5-79 Turn On/Off Circuit. The turn on/off circuit on board A3 can be isolated from the main amplifier driver circuits by disconnecting A3CR3 and/or A3CR4. If the trouble is in the turn on/off circuit, the output should rise to the proper level with the diode(s) disconnected. To check the operation of the turn on/off circuit (diodes A3CR3, CR4, are connected), short the base of A3Q1 to , and the sinewave output will drop to .5V p-p. When the short is removed, the output will return to the full sinewave output.

5-80 Overvoltage Protection Circuit. The overvoltage protection clamping diodes are another potential trouble area. Diodes A3VR1 and VR2 can be lifted (disconnected) individually or together while observing the amplifier output. If one or more are shorted, the complete sinewave will be restored when the defective diode is disconnected.

5-81 Overcurrent Protection Circuit. Protection against overcurrent during the transition from constant voltage to constant current operation is provided by diode A3CR22 on the negative output and diodes A3CR20 and CR21 on the positive output. If these diodes are defective, the output will be badly clipped or the output level will be much lower than normal.

5-82 DEGRADED PERFORMANCE PROBLEMS

5-83 Table 5-4 contains a list of less common troubles and their probable causes. The troubles in this table are less catastrophic than those previously described in that, generally, they lead to degraded performance rather than complete failure.

Table 5-4. Degraded Performance Problems

SYMPTOM	PROBABLE CAUSE
Poor constant voltage line regulation.	Bias and reference supply: Check A1Q1-Q4, A1VR1, A2VR3, A2VR4
Poor constant current line regulation.	Bias and reference supply: Check A1Q1-Q4, A1VR1, A2VR1, A2VR2
Poor constant voltage load regulation.	a. Constant current operation taking place: Check setting of CURRENT control. b. A2U1, A2U2 defective. c. Check measurement technique.
Poor constant current load regulation.	a. CURRENT control set too low. b. A2U3, A2U4 defective. c. Check measurement technique.
High ripple.	a. Ground loop through test equipment, check test setup. b. Excessive ripple in reference voltages. Check reference voltages (Table 5-2). c. Supply crossing over into constant current operation, check setting of CURRENT control (may be set too close to crossover point). d. Defective rectifier circuits (half wave instead of full wave rectification).
Excessive distortion in amplifier modes.	a. Supply crossing over into constant current operation. Check setting of CURRENT control. b. Defective component in amplifier circuit. Check A3CR14-CR17, R29, R30.

5-84 REPAIR AND REPLACEMENT

5-85 Section VI of this manual contains a list of replaceable parts. Table 5-5 contains replacement data for the semiconductors used in the BPS/A described by this manual. When replacing a semiconductor, use a Hewlett-Packard part or a commercial replacement part, if applicable. In cases where neither of these parts are immediately available and a part is needed for emergency operation or troubleshooting verification, the alternate part (see Table 5-5) can be tried with at least a 90% probability of success.

5-86 COVERS AND FRONT PANEL

5-87 Top or Bottom Cover. To remove either the top or bottom cover:

- a. Turn off unit.
- b. Remove two, 1/2-inch, No.6 self-tapping flat-head screws at rear of cover.
- c. Slide cover toward rear of unit approximately 3/4 inches and lift out of unit.

5-88 Side Cover. To remove either side cover, remove four, 1/4-inch, No. 6 flat-head screws and lift cover off.

5-89 Side Castings. To remove either side casting:

- a. Remove top, bottom, and side cover.
- b. Remove eight, No. 6 flat-head screws securing side casting to instrument cross members.
- c. Lift side casting off.

5-90 Front Panel. To remove the front panel:

- a. Remove top, bottom, side covers, and left side casting.
- b. Loosen the VOLTAGE METER and CURRENT METER knobs with allen wrench and remove knobs.
- c. Front panel may now be pulled forward away from front of unit.

5-91 Foot Assemblies and Tilt Stand. The front and rear foot assemblies and the tilt stand on the bottom of the unit must be removed before the unit is rack mounted (see Paragraph 2-15). To remove these assemblies, proceed as follows:

- a. Remove the rear foot assembly on bottom of the unit by pushing the release button in the center of the foot assembly and sliding the assembly OFF as indicated.
- b. Remove bottom cover (Paragraph 5-87). The bottom cover is removed to gain access to the A1 board.

Table 5-5. Semiconductor Replacement Data

Reference Designation	HP Part No.	Commercial Replacement	Alternative
Q1-Q4	1854-0264	2N3715	
A1CR1-CR4; A3CR1-CR7; A2CR1, CR2, CR5, CR10, CR13, CR14, CR18-CR24; A3CR15-CR17, A3CR19-CR21	1901-0050	1N4148	
A1CR5-CR8	1901-0327	1N5059	
A1CR10, CR11, CR16, CR17	1901-0328	1N5060	
A1CR12-CR15	1901-0416	1N4999	
A1CR18	1901-0535	-----	
A1CR20	1901-0518	-----	
A1Q1	1853-0041	2N4036	
A1Q2, A2Q1, Q2, Q3, Q4, Q6; A3Q1, Q4, Q6	1854-0071	-----	2N4141
A1Q3	1854-0244	2N1711A	
A1Q4; A2Q5	1853-0099	-----	2N2907
A1VR1, VR3; A2VR1-5	1902-1221	1N825	
A2CR3, CR4, CR7, CR8, CR11, CR12	1901-0033	1N485	
A2CR9, A3CR14	1901-0460	1N4157	
A2U1-U5	1820-0223	LM301AH National	
A2VR6, VR8	1902-0064	SZ10939-146 Motorola	
A3CR22	1901-0518	-----	
A3Q2, Q7, Q10-Q12, Q14-Q16	1854-0095	40346 RCA	
A3Q3, Q6, Q13, Q17, Q18, Q19	1853-0038	SJ5099 Motorola	
A3Q8, Q9	1853-0037		

NOTE

The release button on the front foot assembly is located directly beneath the -I ZERO ADJ potentiometer on board A1. By pressing slightly inward on the A1 board, sufficient clearance is provided to remove the front foot assembly.

- c. Remove the front foot assembly as in step (a) except also apply slight inward pressure to the A1 board.
- d. Remove one of the side castings (Paragraph 5-89) to allow removal of the tilt stand.
- e. Remove tilt stand.
- f. Replace bottom cover if the unit is to be rack mounted.

5-92 REAR HEAT SINK ASSEMBLY

5-93 In order to remove the power transistors from the heat sink, the rear panels must first be removed. After the rear panels are removed, the transistors are exposed and can be removed. Notice that if a new power transistor is installed, be sure to apply silicon grease (Dow DC-5, HP 8500-0059) to both sides of the transistor's mica insulator to assure proper heat exchange.

5-94 **Rear Panels.** To remove the rear panel containing the rear terminal boards and the panel containing the power receptacle, proceed as described below.

5-95 Terminal Board Panel.

- a. Remove top cover (Paragraph 5-87).
- b. Remove two screws at top of unit (near Service tag).
- c. Remove cable W2 from connector J4 on board A1.
- d. Lift the terminal board panel straight up and out.

5-96 Power Receptacle Panel.

- a. Remove bottom cover (Paragraph 5-87).
- b. Remove two screws securing corner of panel.
- c. Lift panel straight up and out.

5-97 Heat Sink. To remove the heat sink, proceed as follows:

- a. Remove all covers (Paragraph 5-86).
- b. Remove terminal board and power receptacle rear panels (see above).
- c. Remove four screws securing heat sink to side frames.
- d. Remove cable W1 from connector J3 on board A1. The heat sink can now be lifted out.

5-98 ADJUSTMENT AND CALIBRATION

5-99 Adjustment and calibration may be required after performance testing, troubleshooting, or repair and replacement.

5-100 METER ZERO

5-101 The meter pointer must rest on the zero calibration mark on the meter scale when the instrument is at normal operating temperature, resting in its normal operating position, and turned off. To zero set the voltmeter and ammeter, proceed as follows:

- a. Turn on instrument and allow it to come up to normal operating temperature (about 30 minutes).
- b. Turn instrument off. Wait one minute for power supply capacitors to discharge completely.
- c. Insert sharp pointed object (pen point or awl) into small indentation near top of round black plastic disc located directly below meter face.
- d. Rotate plastic disc clockwise until meter reads zero, then rotate counterclockwise slightly in order to free adjustment screw from meter suspension. Pointer should not move during latter part of adjustment.

5-102 CONSTANT VOLTAGE CALIBRATION

NOTE

The CURRENT MODE light should be off during these procedures.

5-103 Output Zero and Offset Adjustments.

- a. Remove top cover to gain access to potentiometers on boards A1 and A2.
- b. Connect DVM to the +S and -S rear terminals.
- c. Short BPS/A front panel input terminals (HI IN to LO IN). Output terminals HI OUT (+) and LO OUT (-) are open circuited.
- d. Set MODE switch to FXD GAIN AMP position. Turn CURRENT control fully clockwise.
- e. Turn on BPS/A and allow a 10-minute warmup.
- f. While switching the RANGE switch between the X1 and X4 positions, adjust A2R60 until the X4 reading on DVM is of the same polarity and 4 times the X1 reading within 2.5mV. For example, if X1 reading is +.1mV, adjust A2R60 for +2.9mV or less.
- g. Set RANGE switch to X1 and adjust A2R61 for $0V \pm 0.25mV$ reading on DVM.
- h. Set RANGE switch to X4, DVM should read $0V \pm 1.0mV$. If not, repeat steps (f) through (g).
- i. Remove short from HI and LO IN terminals.

5-104 Constant Voltage Programming Accuracy.

- a. Set MODE switch to POWER SUPPLY position and RANGE switch to X1 position.
- b. Short terminals A9 and A10 on rear terminal strip.
- c. Adjust potentiometers A2R58 (coarse) and A2R59 (fine) for a DVM reading of $-5.120V \pm .2mV$.
- d. Turn BPS/A off. Remove jumper between terminals A8 and A9 and connect a precision $10.24K\Omega$ ($\pm 0.05\%$) resistor between terminals A9 and A10.
- e. Turn BPS/A on and adjust front panel V ZERO ADJ A1R1 for $0V \pm .2mV$.
- f. Set RANGE switch to X4 position. DVM should read $0V \pm .8mV$. If not, check A2R60 adjustment (step f of Paragraph 5-103).
- g. Turn BPS/A off. Remove $10.24K\Omega$ resistor and connect a $20.48K\Omega$ ($\pm 0.05\%$) resistor between terminals A9 and A10.
- h. Turn BPS/A on. DVM should read $+20.48V \pm 10mV$.

5-105 DC Voltmeter Calibration.

- a. Set VOLTAGE METER switch to the 24V DC position.
- b. Adjust A1R8 for +20.48V indication on BPS/A's front panel voltmeter.
- c. Connect short across $20.48K\Omega$ ($\pm 0.05\%$) resistor (A9 to A10). Front panel voltmeter should read $-20.48V$.
- d. Turn BPS/A off, remove $20.48K$ resistor, install jumper between A8 and A9, remove DVM from output terminals, and replace top cover.

5-106 CONSTANT CURRENT CALIBRATION

NOTE

The CURRENT MODE light should be on during these procedures.

5-107 Constant Current Programming Accuracy.

- a. Remove top cover to gain access to potentiometers on boards A1 and A2.
- b. Remove jumpers from A19 to A20 and from A12 to A13 on rear terminal strip.
- c. Short terminals A18 and A13 and A18 to A20 on rear terminal strip.
- d. Connect a 1Ω .1% precision resistor (R_S) in series with the appropriate high range load resistor (R_L), 49Ω (6826A) or 199Ω (6827A) as shown in Figure 5-16. Connect the DVM across the 1Ω resistor.
- e. Turn on BPS/A and allow a 30-minute warmup.
- f. Set MODE switch to POWER SUPPLY. Set the RANGE switch to X10 and turn the VOLTAGE control fully clockwise.
- g. Adjust front panel + I ZERO ADJ (A1R2) for a reading of $0.000 \pm .3mV$ on DVM.
- h. Turn VOLTAGE control fully counterclockwise.
- i. Adjust front panel - I ZERO ADJ (A1R3) for a reading of $0.000 \pm .3mV$ on DVM.

NOTE

The A1R2 and A1R3 adjustments may interact. Repeat steps (f) through (i) several times to minimize errors.

- j. Turn BPS/A off and remove jumper from A18 to A20. Connect a precision $10.24K$ ($\pm 0.5\%$) resistor between A18 and A20.
- k. Turn VOLTAGE control fully counterclockwise and turn on the BPS/A.
- l. Adjust A2R21 for $-2.048V \pm .5mV$ as indicated on DVM.
- m. Turn BPS/A off and remove the jumper between A18 and A13. Connect a precision $10.24K$ ($\pm 0.5\%$) resistor between A18 and A13.
- n. Turn VOLTAGE control fully clockwise and turn on the BPS/A.

- o. Adjust A2R19 for $+2.048V \pm 5mV$ as indicated on DVM.

5-108 DC Ammeter Calibration.

- a. Set the CURRENT METER switch to the 2.4A DC position.
- b. Adjust A1R20 for a front panel ammeter indication of 2.0A.
- c. Turn off BPS/A. Remove the $10.24K\Omega$ resistors, replace jumpers from A20 to A21 and from A13 to A14. Ensure that jumpers are also connected from A12 to A13 and from A19 to A21. Replace top cover.

5-109 AC METER CALIBRATION

5-110 AC Voltmeter Calibration.

- a. Remove top cover to gain access to potentiometers on board A1.
- b. Connect test setup as shown in Figure 5-16 with high range load resistor (R_L) connected in series with 1Ω resistor (R_S) across + and - output terminals. Set function generator for a 5 volt 100Hz squarewave output.
- c. Set BPS/A front panel controls as follows:
MODE switch: FXD GAIN AMP
RANGE switch: X4
VOLTAGE control: May be left in any position for this procedure.
CURRENT control: fully clockwise
VOLTAGE METER: 16V AC
CURRENT METER: 1.6A AC
- d. Turn on BPS/A and allow a 10-minute warmup.
- e. Connect oscilloscope to +S and -S terminals and observe waveform for overshoot and ringing.
- f. Remove oscilloscope and connect DVM to +S and -S terminals.
- g. Adjust the function generator output level for a DVM reading of $14.1 \pm 0.2V$ rms.
- h. Adjust A1R13 for 14.1V rms on BPS/A front panel voltmeter.

5-111 AC Ammeter Calibration.

- a. Connect DVM across the 1Ω resistor.
- b. Adjust function generator output level for a DVM reading of $1.414 \pm .06V$ rms.
- c. Adjust A1R18 for 1.4A rms on BPS/A front panel ammeter.

SECTION VI REPLACEABLE PARTS

6-1 INTRODUCTION

6-2 This section contains information for ordering replacement parts. Table 6-4 lists parts in alpha-numeric order by reference designators and provides the following information:

- a. Reference Designators. Refer to Table 6-1.
 - b. Description. Refer to Table 6-2 for abbreviations.
 - c. Total Quantity (TQ). Given only the first time the part number is listed except in instruments containing many sub-modular assemblies, in which case the TQ appears the first time the part number is listed in each assembly.
 - d. Manufacturer's Part Number or Type.
 - e. Manufacturer's Federal Supply Code Number.
- Refer to Table 6-3 for manufacturer's name and address.
- f. Hewlett-Packard Part Number.
 - g. Recommended Spare Parts Quantity (RS) for complete maintenance of one instrument during one year of isolated service.
 - h. Parts not identified by a reference designator are listed at the end of Table 6-4 under Mechanical and/or Miscellaneous. The former consists of parts belonging to and grouped by individual assemblies; the latter consists of all parts not immediately associated with an assembly.

6-3 ORDERING INFORMATION

6-4 To order a replacement part, address order or inquiry to your local Hewlett-Packard sales office (see lists at rear of this manual for addresses). Specify the following information for each part: Model, complete serial number, and any Option or special modification (J) numbers of the instrument; Hewlett-Packard part number; circuit reference designator; and description. To order a part not listed in Table 6-4, give a complete description of the part, its function, and its location.

Table 6-1. Reference Designators

A = assembly	E = miscellaneous electronic part
B = blower (fan)	F = fuse
C = capacitor	J = jack, jumper
CB = circuit breaker	K = relay
CR = diode	L = inductor
DS = device, signaling (lamp)	M = meter

Table 6-1. Reference Designators (Continued)

P = plug	V = vacuum tube, neon bulb, photocell, etc.
Q = transistor	VR = zener diode
R = resistor	X = socket
S = switch	Z = integrated circuit or network
T = transformer	
TB = terminal block	
TS = thermal switch	

Table 6-2. Description Abbreviations

A = ampere	mod. = modular or modified
ac = alternating current	mtg = mounting
assy. = assembly	n = nano = 10^{-9}
bd = board	NC = normally closed
bkt = bracket	NO = normally open
$^{\circ}$ C = degree Centigrade	NP = nickel-plated
cd = card	Ω = ohm
coef = coefficient	obd = order by description
comp = composition	OD = outside diameter
CRT = cathode-ray tube	p = pico = 10^{-12}
CT = center-tapped	P.C. = printed circuit
dc = direct current	pot. = potentiometer
DPDT = double pole, double throw	p-p = peak-to-peak
DPST = double pole, single throw	ppm = parts per million
elect = electrolytic	pvr = peak reverse voltage
encap = encapsulated	rect = rectifier
F = farad	rms = root mean square
$^{\circ}$ F = degree Fahrenheit	Si = silicon
fxd = fixed	SPDT = single pole, double throw
Ge = germanium	SPST = single pole, single throw
H = Henry	SS = small signal
Hz = Hertz	T = slow-blow
IC = integrated circuit	tan. = tantalum
ID = inside diameter	Ti = titanium
incnd = incandescent	V = volt
k = kilo = 10^3	var = variable
m = milli = 10^{-3}	ww = wirewound
M = mega = 10^6	W = Watt
μ = micro = 10^{-6}	
met. = metal	
mfr = manufacturer	

Table 6-3. Code List of Manufacturers

CODE	MANUFACTURER	ADDRESS	CODE	MANUFACTURER	ADDRESS
00629	EBY Sales Co., Inc.	Jamaica, N.Y.	07137	Transistor Electronics Corp.	Minneapolis, Minn.
00656	Aerovox Corp.	New Bedford, Mass.	07138	Westinghouse Electric Corp.	Elmira, N.Y.
00853	Sangamo Electric Co.		07263	Fairchild Camera and Instrument	Mountain View, Calif.
	S. Carolina Div.	Pickens, S.C.	07387	Birtcher Corp., The	Los Angeles, Calif.
01121	Allen Bradley Co.	Milwaukee, Wis.	07397	Sylvania Electric Prod. Inc.	Mountainview, Calif.
01255	Litton Ind.	Beverly Hills, Calif.	07716	IRC Div. of TRW Inc.	Burlington, Iowa
01281	TRW Semiconductors, Inc.	Lawndale, Calif.	07910	Continental Device Corp.	Hawthorne, Calif.
01295	Texas Instruments, Inc.	Dallas, Texas	07933	Raytheon Co. Components Div.	Mountain View, Calif.
01686	RCL Electronics, Inc.	Manchester, N.H.	08484	Breeze Corporations, Inc.	Union, N.J.
01930	Amerock Corp.	Rockford, Ill.	08530	Reliance Mica Corp.	Brooklyn, N.Y.
02107	Sparta Mfg. Co.	Dover, Ohio	08717	Sloan Company, The	Sun Valley, Calif.
02114	Ferroxcube Corp.	Saugerties, N.Y.	08730	Vemaline Products Co. Inc.	Wyckoff, N.J.
02606	Fenwal Laboratories	Morton Grove, Ill.	08806	General Elect. Co. Minature	
02660	Amphenol Corp.	Broadview, Ill.		Lamp Dept.	Cleveland, Ohio
02735	Radio Corp. of America, Solid State and		08863	Nylomatic Corp.	Norrisville, Pa.
	Receiving Tube Div.	Somerville, N.J.	08919	RCH Supply Co.	Vernon, Calif.
03508	G.E. Semiconductor Products Dept.		09021	Airco Speer Electronic Components	Bradford, Pa.
		Syracuse, N.Y.	09182	*Hewlett-Packard Co. New Jersey Div.	Rockaway, N.J.
03797	Eldema Corp.	Compton, Calif.	09213	General Elect. Co. Semiconductor	
03877	Transitron Electronic Corp.	Wakefield, Mass.		Prod. Dept.	Buffalo, N.Y.
03888	Pyrofilm Resistor Co., Inc.	Cedar Knolls, N.J.	09214	General Elect. Co. Semiconductor	
04009	Arrow, Hart and Hegeman Electric Co.	Hartford, Conn.		Prod. Dept.	Auburn, N.Y.
04072	ADC Electronics, Inc.	Harbor City, Calif.	09353	C & K Components Inc.	Newton, Mass.
04213	Caddell & Burns Mfg. Co. Inc.	Mineola, N.Y.	09922	Burndy Corp.	Norwalk, Conn.
04404	*Hewlett-Packard Co. Palo Alto Div.	Palo Alto, Calif.	11115	Wagner Electric Corp.	
04713	Motorola Semiconductor Prod. Inc.	Phoenix, Arizona		Tung-Sol Div.	Bloomfield, N.J.
05277	Westinghouse Electric Corp.		11236	CTS of Berne, Inc.	Berne, Ind.
	Semiconductor Dept.	Youngwood, Pa.	11237	Chicago Telephone of Cal. Inc.	So. Pasadena, Calif.
05347	Ultronix, Inc.	Grand Junction, Colo.	11502	IRC Div. of TRW Inc.	Boone, N.C.
05820	Wakefield Engr. Inc.	Wakefield, Mass.	11711	General Instrument Corp.	Newark, N.J.
06001	General Elect. Co. Electronic		12136	Philadelphia Handle Co.	Camden, N.J.
	Capacitor & Battery Dept.	Irmo, S.C.	12615	U.S. Terminals, Inc.	Cincinnati, Ohio
06004	Bassik Div. Stewart-Warner Corp.	Bridgeport, Conn.	12617	Hamlin Inc.	Lake Mills, Wisconsin
06486	IRC Div. of TRW Inc.		12697	Claroostat Mfg. Co. Inc.	Dover, N.H.
	Semiconductor Plant	Lynn, Mass.	13103	Thermalloy Co.	Dallas, Texas
06540	Amatom Electronic Hardware Co. Inc.	New Rochelle, N.Y.	14493	*Hewlett-Packard Co.	Loveland, Colo.
06555	Beede Electrical Instrument Co.	Penacook, N.H.	14655	Cornell-Dubilier Electronics Div.	
06666	General Devices Co.	Indianapolis, Ind.		Federal Pacific Electric Co.	Newark, N.J.
06751	Semoor Div. Components, Inc.	Phoenix, Arizona	14936	General Instrument Corp. Semicon-	
06776	Robinson Nugent, Inc.	New Albany, N.Y.		ductor Prod. Group	Hicksville, N.Y.
06812	Torrington Mfg. Co.	Van Nuys, Calif.	15801	Fenwal Elect.	Framingham, Mass.
			16299	Corning Glass Works	Raleigh, N.C.

*Use Code 28480 assigned to Hewlett-Packard Co., Palo Alto, California

Table 6-3. Code List of Manufacturers

CODE	MANUFACTURER	ADDRESS	CODE	MANUFACTURER	ADDRESS
16758	Delco Radio Div. of General Motors Corp.	Kokomo, Ind.	59730	Thomas and Betts Co.	Philadelphia, Pa.
17545	Atlantic Semiconductors, Inc.	Asbury Park, N.J.	61637	Union Carbide Corp.	New York, N.Y.
17803	Fairchild Camera and Instrument Corp.	Mountain View, Calif.	63743	Ward Leonard Electric Co.	Mt. Vernon, N.Y.
17870	Daven Div. Thomas A. Edison Industries	Orange, N.J.	70563	Amperite Co. Inc.	Union City, N.J.
18324	Signetics Corp.	Sunnyvale, Calif.	70901	Beemer Engrg Co.	Fort Washington, Pa.
19315	Bendix Corp. The Navigation and Control Div.	Teterboro, N.J.	70903	Belden Corp.	Chicago, Ill.
19701	Electra/Midland Corp.	Mineral Wells, Texas	71218	Bud Radio, Inc.	Willoughby, Ohio
21520	Fansteel Metallurgical Corp.	No. Chicago, Ill.	71279	Cambridge Thermionic Corp.	Cambridge, Mass.
22229	Union Carbide Corp. Electronics Div.	Mountain View, Calif.	71400	Bussmann Mfg. Div. of McGraw & Edison Co.	St. Louis, Mo.
22753	UID Electronics Corp.	Hollywood, Fla.	71450	CTS Corp.	Elkhart, Ind.
23936	Pamotor, Inc.	Pampa, Texas	71468	I.T.T. Cannon Electric Inc.	Los Angeles, Calif.
24446	General Electric Co.	Schenectady, N.Y.	71590	Globe-Union Inc.	Milwaukee, Wis.
24455	General Electric Co.	Nela Park, Cleveland, Ohio	71700	General Cable Corp. Cornish Wire Co. Div.	Williamstown, Mass.
24655	General Radio Co.	West Concord, Mass.	71707	Coto Coil Co. Inc.	Providence, R.I.
24681	LTV Electrosystems Inc. Memcor/Components Operations	Huntington, Ind.	71744	Chicago Miniature Lamp Works	Chicago, Ill.
26982	Dynacool Mfg. Co. Inc.	Saugerties, N.Y.	71785	Cinch Mfg. Co. and Howard B. Jones Div.	Chicago, Ill.
27014	National Semiconductor Corp.	Santa Clara, Calif.	71984	Dow Corning Corp.	Midland, Mich.
28480	Hewlett-Packard Co.	Palo Alto, Calif.	72136	Electro Motive Mfg. Co. Inc.	Willimantic, Conn.
28520	Heyman Mfg. Co.	Kenilworth, N.J.	72619	Dialight Corp.	Brooklyn, N.Y.
28875	IMC Magnetics Corp.	Rochester, N.H.	72699	General Instrument Corp.	Newark, N.J.
31514	SAE Advance Packaging, Inc.	Santa Ana, Calif.	72765	Drake Mfg. Co.	Harwood Heights, Ill.
31827	Budwig Mfg. Co.	Ramona, Calif.	72962	Elastic Stop Nut Div. of Amerace Esna Corp.	Union, N.J.
33173	G.E. Co. Tube Dept.	Owensboro, Ky.	72982	Erie Technological Products	Erie, Pa.
35434	Lectrohm, Inc.	Chicago, Ill.	73096	Hart Mfg. Co.	Hartford, Conn.
37942	P.R. Mallory & Co.	Indianapolis, Ind.	73138	Beckman Instruments	Fullerton, Calif.
42190	Muter Co.	Chicago, Ill.	73168	Fenwal, Inc.	Ashland, Mass.
43334	New Departure-Hyatt Bearings Div. General Motors Corp.	Sandusky, Ohio	73293	Hughes Aircraft Co. Electron Dynamics Div.	Torrance, Calif.
44655	Ohmite Manufacturing Co.	Skokie, Ill.	73445	Amperex Electronic	Hicksville, N.Y.
46384	Penn Engr. and Mfg. Corp.	Doylestown, Pa.	73506	Bradley Semiconductor Corp.	New Haven, Conn.
47904	Polaroid Corp.	Cambridge, Mass.	73559	Carling Electric, Inc.	Hartford, Conn.
49956	Raytheon Co.	Lexington, Mass.	73734	Federal Screw Products, Inc.	Chicago, Ill.
55026	Simpson Electric Co. Div. of American Gage and Machine Co.	Chicago, Ill.	74193	Heinemann Electric Co.	Trenton, N.J.
56289	Sprague Electric Co.	North Adams, Mass.	74545	Hubbell Harvey Inc.	Bridgeport, Conn.
58474	Superior Electric Co.	Bristol, Conn.	74868	Amphenol Corp. Amphenol RF Div.	Danbury, Conn.
58849	Syntron Div. of FMC Corp.	Homer City, Pa.	74970	E.F. Johnson Co.	Waseca, Minn.

Table 6-3. Code List of Manufacturers

CODE	MANUFACTURER	ADDRESS	CODE	MANUFACTURER	ADDRESS
75042	IRC Div. of TRW, Inc.	Philadelphia, Pa.	82866	Research Products Corp.	Madison, Wisc.
75183	*Howard B. Jones Div. of Cinch Mfg. Corp.	New York, N.Y.	82877	Rotron Inc.	Woodstock, N.Y.
75376	Kurz and Kasch, Inc.	Dayton, Ohio	82893	Vector Electronic Co.	Glendale, Calif.
75382	Kilka Electric Corp.	Mt. Vernon, N.Y.	83058	Carr Fastener Co.	Cambridge, Mass.
75915	Littlefuse, Inc.	Des Plaines, Ill.	83186	Victory Engineering	Springfield, N.J.
76381	Minnesota Mining and Mfg. Co.	St. Paul, Minn.	83298	Bendix Corp.	Eatontown, N.J.
76385	Minor Rubber Co. Inc.	Bloomfield, N.J.	83330	Herman H. Smith, Inc.	Brooklyn, N.Y.
76487	James Millen Mfg. Co. Inc.	Malden, Mass.	83385	Central Screw Co.	Chicago, Ill.
76493	J.W. Miller Co.	Compton, Calif.	83501	Gavitt Wire and Cable	Brookfield, Mass.
76530	Cinch	City of Industry, Calif.	83508	Grant Pulley and Hardware Co.	West Nyack, N.Y.
76854	Oak Mfg. Co. Div. of Oak Electro/ Netics Corp.	Crystal Lake, Ill.	83594	Burroughs Corp.	Plainfield, N.J.
77068	Bendix Corp., Electrodynamics Div.	No. Hollywood, Calif.	83835	U.S. Radium Corp.	Morristown, N.J.
77122	Palnut Co.	Mountainside, N.J.	83877	Yardeny Laboratories	New York, N.Y.
77147	Patton-MacGuyer Co.	Providence, R.I.	84171	Arco Electronics, Inc.	Great Neck, N.Y.
77221	Phaostron Instrument and Electronic Co.	South Pasadena, Calif.	84411	TRW Capacitor Div.	Ogallala, Neb.
77252	Philadelphia Steel and Wire Corp.	Philadelphia, Pa.	86684	RCA Corp.	Harrison, N.J.
77342	American Machine and Foundry Co.	Princeton, Ind.	86838	Rummel Fibre Co.	Newark, N.J.
77630	TRW Electronic Components Div.	Camden, N.J.	87034	Marco & Oak Industries	Anaheim, Calif.
77764	Resistance Products Co.	Harrisburg, Pa.	87216	Philco Corp.	Lansdale, Pa.
78189	Illinois Tool Works Inc.	Elgin, Ill.	87585	Stockwell Rubber Co.	Philadelphia, Pa.
78452	Everlook Chicago, Inc.	Chicago, Ill.	87929	Tower-Olschan Corp.	Bridgeport, Conn.
78488	Stackpole Carbon Co.	St. Marys, Pa.	88140	Cutler-Hammer Inc.	Lincoln, Ill.
78526	Stanwyck Winding Div. San Fernando Electric Mfg. Co. Inc.	Newburgh, N.Y.	88245	Litton Precision Products Inc, USECO	Van Nuys, Calif.
78553	Tinnerman Products, Inc.	Cleveland, Ohio	90634	Gulton Industries Inc.	Metuchen, N.J.
78584	Stewart Stamping Corp.	Yonkers, N.Y.	90763	United-Car Inc.	Chicago, Ill.
79136	Waldes Kohinoor, Inc.	L.I.C., N.Y.	91345	Miller Dial and Nameplate Co.	El Monte, Calif.
79307	Whitehead Metals Inc.	New York, N.Y.	91418	Radio Materials Co.	Chicago, Ill.
79727	Continental-Wirt Electronics Corp.	Philadelphia, Pa.	91506	Augat, Inc.	Attleboro, Mass.
79963	Zierick Mfg. Co.	Mt. Kisco, N.Y.	91637	Dale Electronics, Inc.	Columbus, Neb.
80031	Mepco	Morristown, N.J.	91662	Elco Corp.	Willow Grove, Pa.
80294	Bourns, Inc.	Riverside, Calif.	91929	Honeywell Inc.	Freeport, Ill.
81042	Howard Industries	Racine, Wisc.	92825	Whitso, Inc.	Schiller Pk., Ill.
81073	Grayhill, Inc.	La Grange, Ill.	93332	Sylvania Electric Prod.	Woburn, Mass.
81483	International Rectifier	El Segundo, Calif.	93410	Essex Wire Corp.	Mansfield, Ohio
81751	Columbus Electronics	Yonkers, N.Y.	94144	Raytheon Co.	Quincy, Mass.
82099	Goodyear Sundries & Mechanical Co. Inc.	New York, N.Y.	94154	Wagner Electric Corp.	Livingston, N.J.
82142	Airco Speer Electronic Components	Du Bois, Pa.	94222	Southco Inc.	Lester, Pa.
82219	Sylvania Electric Products Inc.	Emporium, Pa.	95263	Leecraft Mfg. Co. Inc.	L.I.C., N.Y.
82389	Switchcraft, Inc.	Chicago, Ill.	95354	Methode Mfg. Co.	Rolling Meadows, Ill.
82647	Metals and Controls Inc.	Attleboro, Mass.	95712	Bendix Corp.	Franklin, Ind.
			95987	Weckesser Co. Inc.	Chicago, Ill.
			96791	Amphenol Corp.	Janesville, Wis.
			97464	Industrial Retaining Ring Co.	Irvington, N.J.
			97702	IMC Magnetics Corp.	Westbury, N.Y.
			98291	Sealectro Corp.	Mamaroneck, N.Y.
			98410	ETC Inc.	Cleveland, Ohio
			98978	International Electronic Research Corp.	Burbank, Calif.
			99934	Renbrandt, Inc.	Boston, Mass.

*Use Code 71785 assigned to Cinch Mfg. Co., Chicago, Ill.

Table 6-4. Replaceable Parts

REF. DESIG.	DESCRIPTION	TQ	MFR. PART NO.	MFR. CODE	HP PART NO.	RS
A1	Interconnect and Power Supply Board	1		28480	06825-60020	
C1	Not Assigned					
C2	fxd, elect. 100 μ F 25Vdc	1	30D107G025DD2-DSM	56289	0180-0094	1
C3,4	fxd, elect. 325 μ F 35Vdc	2	D34656-DEE	56289	0180-0332	1
C5-7	fxd, cer. .05 μ F 400Vdc	8	33C17A3-CDH	56289	0150-0052	2
C8	fxd, elect. 200 μ F 175Vdc	2	68D10223	56289	0180-1885	1
C9	fxd, cer. .05 μ F 400Vdc		33C17A3-CDH	56289	0150-0052	
C10	fxd, elect. 6000 μ F 50Vdc	2	36D7890	56289	0180-0449	1
C11-14	fxd, cer. 0.5 μ F 400Vdc		33C17A3-CDH	56289	0150-0052	
C15	fxd, elect. 6000 μ F 50Vdc		36D7890	56289	0180-0449	
C16	fxd, elect. 200 μ F 175Vdc		68D10223	56289	0180-1885	
C17,18	fxd, cer. .47 μ F 25Vdc	2	5C11B7-CML	56289	0160-0174	1
CR1-4	Diode, Si. 200mA 75V	4	1N4148	28480	1901-0050	4
CR5-8	Diode, Si. 200prv 1A	8	1N5095	28480	1901-0327	5
CR9	Not Assigned					
CR10-11	Diode, Si. 400V 1A	4	1N5060	03508	1901-0328	4
CR12-15	Diode, Si. 200V 1.5A	4	1N4999	04713	1901-0416	4
CR16,17	Diode, Si. 400V 1A		1N5060	03508	1901-0328	
CR18	Diode, Hot Carrier	1		28480	1901-0535	1
CR19	Not Used (Jumper)					
CR20	Diode, Hot Carrier	1		28480	1901-0518	1
J1,2	Connector, Printed Circuit Edge	2	252-18-30-340	71785	1251-2134	1
J3,4	Connector, Multi-contact	2	3428-2002	76381	1251-3119	1
K1	Relay, 6Vdc coil voltage	1	603-6	09023	0490-0745	1
Q1	Power PNP Si.	1	2N4036	02735	1853-0041	1
Q2	SS NPN Si.	1	2N4141	01295	1854-0071	1
Q3	Power NPN Si.	1	2N1711A	28480	1854-0244	1
Q4	SS PNP Si.	1	2N2907	56289	1853-0099	1
R1,2,3	var, ww, 100, 5%, 1W	3	CT-106-4	84048	2100-1755	1
R4	fxd, comp. 22K 5% 1/2W	2	EB-2235	01121	0686-2235	1
R5,6	fxd, comp. 2K 5%, 1W	2	GB2025	01121	0689-2025	1
R7	fxd, comp. 22K 5%, 1/2W		EB2235	01121	0686-2235	
R8	var, ww 5K 5%, 1W	2	CT-100-4	84048	2100-0741	1
R9,10	fxd, film 3K 1%, 1/8W	3	CEA T-0	07716	0757-1093	1
R11	fxd, film, 34.8K 1%, 1/8W	1	CEA T-0	07716	0757-0123	1
R12	Not Used (Jumper)					
R13	var, ww, 5K 5%, 1W		CT-100-4	84048	2100-0741	
R14	fxd, film, 3K 1%, 1/8W		CEA T-0	07716	0757-1093	1
R15	Not Used,(Jumper)					
R16	fxd, film, 11.3K 1%, 1/8W	1	CEA T-0	07716	0698-4121	1
R17	fxd, film, 1.69K 1%, 1/8W	1	CEA T-0	07716	0698-4428	1
R18	var, ww, 200, 5%, 1W	2	CT-100-4	84048	2100-1771	1
R19	fxd, film, 1.69K 1%, 1/8W		CEA T-0	07716	0698-4428	
R20	var, ww, 200, 5%, 1W		CT-100-4	84048	2100-1771	
R21	fxd, film, 2.37K 1%, 1/8W	1	CEA T-0	07716	0698-3150	1
R22	fxd, film, 100K 1%, 1/8W	1	CEA T-0	07716	0757-0401	1
R23	fxd, film, 471, 1%, 1/8W	1	CEA T-0	07716	0698-5541	1
R24	fxd, film, 6.2K 1%, 1/8W		CEA T-0	07716	0698-5087	
R25	fxd, comp. 4.3K 5%, 1/2W	1	EB-4325	01121	0686-4325	1

Table 6-4. Replaceable Parts

REF. DESIG.	DESCRIPTION	TQ	MFR. PART NO.	MFR. CODE	HP PART NO.	RS
A1R26	fxd, comp. 7.5K 5%, 1/8W	2	EB-7525	01121	0686-7525	1
R27	fxd, comp. 750, 5%, 1/8W	1	EB-7515	01121	0686-7515	1
R28	fxd, comp. 1K 5%, 1/8W	1	EB-1025	01121	0686-1025	1
R29	fxd, film, 3.92K 1%, 1/8W	1	CEA T-0	07716	0757-0435	1
R30	fxd, film, 6.81K 1%, 1/8W	1	CEA T-0	07716	0757-0439	1
R31	fxd, comp. 7.5K 5%, 1/8W	2	EB-7525	01121	0686-7525	1
R32	fxd, film, 1.3K 1%, 1/8W	1	CCA T-0	07716	0757-0735	1
R33	Not Assigned					
R34	fxd, film, 5.49K 1%, 1/8W	1	CEA T-0	07716	0698-3382	1
R35	Not Assigned					
R36	fxd, film, 9.09K 1%, 1/8W		CEA T-0	07716	0757-0288	
R37	fxd, comp. 620, 5%, 1/8W	1	EB-6215	01121	0686-6215	1
R38	fxd, ww, 400, 5%, 5W	1	243E	56289	0811-1857	1
R39	fxd, ww, 500, 5%, 5W	1	243E	56289	0811-1858	1
R40	Not Assigned					
R41	fxd, film, 10K 1%, 1/8W	1	CEA T-0	07716	0757-0442	1
R42	fxd, ww, 10.24K .05%, 1/8W	1	132F	20940	0811-2958	1
R43	fxd, comp. 1.3K 5%, 1/8W	1	EB-1325	01121	0686-1325	1
R44,45	fxd, film, 21.5, 1%, 1/8W	4	CEA T-0	07716	0698-3430	4
R46-50	Not Assigned					
R51,52	fxd, film, 42.2K 1%, 1/8W	2	CEA T-0	07716	0698-3450	2
R53	fxd, film, 160K 1%, 1/8W	1	CEA T-0	07716	0698-5092	1
R54	fxd, film, 42.2, 1%, 1/8W	1	CEA T-0	07716	0757-0316	1
R55	Thermistor, 64, 10%	1	LB16J1	02606	0837-0023	1
R56	fxd, film, 3.16K, 1%, 1/8W	1	CEA T-0	07716	0757-0279	1
R57	Not Assigned					
R58	fxd, film, 1K, 1%, 1/8W	1	CEA T-0	07716	0757-0280	1
R59	Not Assigned					
R60	fxd, ww, 1, 5%, 3W	1	242E 1R05	56289	0811-1732	1
R61-65	Not Assigned					
R66-69	fxd, film, 6K, 1%, 1/8W	4	CEA T-0	07716	0698-3476	4
R70,71	fxd, film, 21.5, 1%, 1/8W		CEA T-0	07716	0698-3430	
S1,2	Switch, rotary, 3 sections	2		28480	3100-1941	2
VR1	Diode, zener 6.2V	2	1N825	28480	1902-1221	2
VR2	Not Assigned					
VR3	Diode, zener 6.2V		1N825	28480	1902-1221	
A2	Voltage and Current Control Plug-In Board	1		28480	06825-60021	
C1	fxd, mica, 30pF, 5%, 300V	5	RDM15E300J3S	00853	0160-0181	1
C3	fxd, cer., 390pF, 1%, 500V	1	DD472	71590	0160-0474	1
C4,5	fxd, mica, 30pF, 5%, 300V		RDM15E300J3S	00853	0160-0181	
C6	fxd, cer., .01μF 1KV		C023A102J103MS38-CDH	56289	0150-0012	
C7	fxd, cer., 3900pF, 5%, 500V	1		28480	0160-2723	1
C8	fxd, mica, 30pF, 5%, 300V		RDM15E300J3S	00853	0160-0181	
C9	fxd, mylar, .001μF, 10%, 200V	1	292P10292-PTS	56289	0160-0153	1
C10	fxd, tant. 2.2μF, 20Vdc	1	150D225X0020A2-DYS	56289	0180-0155	1
C11,12	fxd, mylar, .015μF, 10%, 200V	2	292P15392-PTS	56289	0160-0194	2
C13	fxd, elect. 100μF, 6Vdc	1	30D107G006CC2-DSM	56289	0180-1734	1

Table 6-4. Replaceable Parts

REF. DESIG.	DESCRIPTION	TQ	MFR. PART NO.	MFR. CODE	HP PART NO.	RS
A2C14	fxd, mica, 30pF, 5%, 300V		RDM15E300J3S	00853	0160-0181	
CR1,2	Diode, Si. 200mA 75V	13	1N4148	28480	1901-0050	7
CR3,4	Diode, Si. 250mW 200prv	6	1N485	28480	1901-0033	5
CR5	Diode, Si. 200mA 75V		1N4148	28480	1901-0050	
CR6	Not Assigned					
CR7,8	Diode, Si. 250mW 200prv		1N485	28480	1901-0033	
CR9	Stabistor, Si. 10prv 400mW		1N4157	28480	1901-0460	
CR10	Diode, Si. 200mA 75V		1N4148	28480	1901-0050	1
CR11,12	Diode, Si. 250mW 200prv		1N485	28480	1901-0033	
CR13,14	Diode, Si. 200mA 75V		1N4148	28480	1901-0050	
CR15-17	Not Assigned					
CR18-24	Diode, Si. 200mA, 75V		1N4148	28480	1901-0050	
K1	Reed Relay	1		28480	0490-1013	1
K2,3	Reed Relay	2		28480	0490-0399	2
Q1-4	SS NPN Si.	5	2N4141	01295	1854-0071	5
Q5	SS PNP Si.	1	2N2907	56289	1853-0099	1
Q6	SS NPN Si.		2N4141	01295	1854-0071	
R1,2	fxd, film, 1K 1%, 1/8W	7	CEA T-0	07716	0757-0280	1
R3	fxd, ww, 714, 1%, 1/8W	1	R303B	01686	0811-1935	1
R4	fxd, film, 1K, 1%, 1/8W		CEA T-0	07716	0757-0280	
R5	fxd, film, 6K, 1%, 1/8W	5	CEA T-0	07716	0698-3476	1
R6,7	fxd, ww, 10.24K .05%, 1/8W	2	132F	20940	0811-2958	1
R8	fxd, film, 6K, 1%, 1/8W		CEA T-0	07716	0698-3476	
R9	fxd, ww, 20.48K, .05%, 1/8W	1	132F	20940	0811-2959	
R10	fxd, film, 6K, 1%, 1/8W		CEA T-0	07716	0698-3476	
R11,12	fxd, film, 100, 1%, 1/8W	4	CEA T-0	07716	0757-0401	1
R13	fxd, film, 4.75K, 1%, 1/8W	1	CEA T-0	07716	0757-0437	1
R14	fxd, film, 3K, 1%, 1/8W	1	CEA T-0	07716	0757-1093	1
R15	fxd, film, 1K, 1%, 1/8W		CEA T-0	07716	0757-0280	
R16	fxd, ww, 10.24K, .05%, 1/8W		132F	20940	0811-2958	
R17,18	fxd, film, 1.18K, 1%, 1/8W	2	CEA T-0	07716	0698-3512	1
R19	var, ww, 10K, 5%, 1W	2	CT-106-4	11502	2100-0989	1
R20	fxd, film, 57.6K, 1%, 1/8W	2	CCA T-0	07716	0757-0114	1
R21	var, ww 10K, 5%, 1W		CT-106-4	11502	2100-0989	
R22	fxd, film, 57.6K, 1%, 1/8W		CCA T-0	07716	0757-0114	
R23	Not Used (Jumper)					
R24	fxd, comp. 3.9, 5%, 1/8W	1	EB-39G5	01121	0698-5139	1
R25	fxd, film, 200K, 1%, 1/8W	1	CEA T-0	07716	0757-0472	1
R26	Not Used (Jumper)					
R27	fxd, ww, 0.5, .5%, 8W	1	T7A	01686	0811-2103	1
R28,29	fxd, film, 383K, 1%, 1/8W	2	CEA T-0	07716	0698-3459	1
R30,31	Not Assigned					
R32,33	fxd, film, 9.09K, 1%, 1/8W	2	CEA T-0	07716	0757-0288	2
R34	fxd, film, 12K, 1%, 1/8W	1	CEA T-0	07716	0698-5088	1
R35	fxd, film, 2K, 1%, 1/8W	3	CEA T-0	07716	0757-0283	1
R36	fxd, film, 8.25K, 1%, 1/8W	2	CEA T-0	07716	0757-0441	1
R37,38	fxd, film, 21.5, 1%, 1/8W	2	CEA T-0	07716	0757-3430	1
R39	fxd, film, 8.25K, 1%, 1/8W		CEA T-0	07716	0757-0441	

Table 6-4. Replaceable Parts

REF. DESIG.	DESCRIPTION	TQ	MFR. PART NO.	MFR. CODE	HP PART NO.	RS
A2R40	fxd, comp. 82, 5%, 1/2W	1	EB-8205	01121	0686-8205	1
R41	fxd, film, 5.11K, 1%, 1/8W	2	CEA T-0	07716	0757-0438	1
R42	fxd, ww, 10.24K, .05%, 1/2W		132F	20940	0811-2958	
R43,44	Not Assigned					
R45	fxd, film, 3K, 1%, 1/8W	2	CEA T-0	07716	0757-1093	1
R46	fxd, film, 7.5K, 1%, 1/8W	2	CEA T-0	07716	0757-0440	1
R47	fxd, film, 6.2K, 1%, 1/8W		CEA T-0	07716	0698-5087	
R48	fxd, film, 5.11K, 1%, 1/8W		CEA T-0	07716	0757-0438	
R49	fxd, film, 15K, 1%, 1/8W	1	CEA T-0	07716	0757-0446	1
R50	fxd, comp: 1K, 5%, 1/2W	1	EB-1025	01121	0686-1025	1
R51	fxd, film, 6K, 1%, 1/8W		CEA T-0	07716	0698-3476	
R52,53	fxd, film, 100, 1%, 1/8W		CEA T-0	07716	0757-0401	
R54	fxd, film, 6K, 1%, 1/8W		CEA T-0	07716	0698-3476	
R55	fxd, film, 27.4K, 1%, 1/8W	1	CEA T-0	07716	0757-0452	1
R56	fxd, film, 2K, 1%, 1/8W		CEA T-0	07716	0757-0283	
R57	fxd, film, 7.5K, 1%, 1/8W		CEA T-0	07716	0757-0440	
R58	var, ww, 1K, 5%, 1W	1	CT-106-4	84048	2100-1758	1
R59	var, ww, 10, 5%, 1W	1	CT-106-4	84048	2100-1752	1
R60,61	var, ww, 100, 5%, 1W	2	CT-106-4	84048	2100-1755	1
R62	Not Assigned					
R63	fxd, film, 3.83K, 1%, 1/8W	2	CEA T-0	07716	0698-3153	1
R64	fxd, film, 2.15K, 1%, 1/8W	2	CEA T-0	07716	0698-0084	1
R65	fxd, film, 3.83K, 1%, 1/8W		CEA T-0	07716	0698-3153	
R66	fxd, film, 2.15K, 1%, 1/8W		CEA T-0	07716	0698-0084	
R67-70	Not Assigned					
R71,72	fxd, film, 1K, 1%, 1/8W		CEA T-0	07716	0757-0280	
R73	fxd, film, 6.81K, 1%, 1/8W		CEA T-0	07716	0757-0439	
R74	fxd, film, 1K, 1%, 1/8W		CEA T-0	07716	0757-0280	
R75	fxd, film, 5.49K, 1%, 1/8W	1	CEA T-0	07716	0698-3382	1
R76	fxd, film, 24.3K, 1%, 1/8W	2	CEA T-0	07716	0757-0451	1
R77	fxd, film, 2.43K, 1%, 1/8W	1	CEA T-0	07716	0757-0431	1
R78	fxd, film, 24.3K, 1%, 1/8W		CEA T-0	07716	0757-0451	
R79	fxd, film, 2K, 1%, 1/8W		CEA T-0	07716	0757-0283	
S1	Slide Switch, 0.5A, 125Vac/dc	1	GF126-0020	79727	3101-1311	1
VR1-5	Diode, zener 6.2V	5	1N825	28480	1902-1221	5
VR6	Diode, zener 7.50V 400mW	2	SZ10939-146	04713	1902-0064	2
VR7	Not Assigned					
VR8	Diode, zener 7.50V 400mW		SZ10939-146	04713	1902-0064	
U1-5	IC, Linear Amplifier	5	LM301AH	27014	1820-0223	5
A3	Power Amplifier Plug-In Board	1		28480	06825-60022	
C1	fxd, elect. 20 μ F 15Vdc	1	30D206G016BB2-DSM	56289	0180-0300	1
C2	fxd, elect. 1 μ F 35Vdc	1	150D105X9035A2	56289	0180-0291	1
C3-6	Not Assigned					
C7	fxd, cer., .22 μ F 50Vdc	1	5C52B-CML	56289	0160-0263	1
C8	fxd, cer., .02 μ F 500Vdc	2	C023B501J203Z825	56289	0160-0468	1
C9	fxd, mica, 150pF 300Vdc	1	RDM15F151J3C	00853	0140-0196	1
C10	fxd, mica, 470pF 500Vdc	1		00853	0140-0149	1
C11	fxd, mylar, .001 μ F 200Vdc	1	192P10292	56289	0160-0153	1

Table 6-4. Replaceable Parts

REF. DESIG.	DESCRIPTION	TQ	MFR. PART NO.	MFR. CODE	HP PART NO.	RS
A3C12,13	fxd, mylar .047 μ F 200Vdc	2	292P47352-PTS	56289	0160-0138	1
C14	fxd, cer., .02 μ F 500Vdc		C023B501J203ZS25	56289	0160-0468	
C15	fxd, cer., 5000pF 1KV	1	C023B102G502ZS31-CDH	56289	0160-0899	1
CR1-7	Diode, Si. 200mA 75V	13	1N4148	28480	1901-0050	7
CR8-13	Not Assigned					
CR14	Stabistor, Si. 10prv 400mW	1	1N4157	28480	1901-0460	1
CR15-17	Diode, Si. 200mA 75V		1N4148	28480	1901-0050	
CR18	Not Assigned					
CR19-21	Diode, Si. 200mA 75V		1N4148	28480	1901-0050	
CR22	Diode, Hot Carrier	1		28480	1901-0518	1
Q1	SS NPN Si.	3	2N4141	28480	1854-0071	3
Q2	SS NPN Si.	8	40346	86684	1854-0095	8
Q3	SS PNP Si.	6	SJ5099	04713	1853-0038	6
Q4,5	SS NPN Si.		2N4141	28480	1854-0071	
Q6	SS PNP Si.		SJ5099	04713	1853-0038	
Q7	SS NPN Si.		40346	86684	1854-0095	
Q8,9	SS PNP Si.	2		28480	1853-0037	2
Q10-12	SS NPN Si.		40346	86684	1854-0095	
Q13	SS PNP Si.		SJ5099	04713	1853-0038	
Q14-16	SS NPN Si.		40346	86684	1854-0095	
Q17-19	SS PNP Si.		SJ5099	04713	1853-0038	
R1,2	fxd, comp, 15K, 5%, $\frac{1}{2}$ W	2	EB-1535	01121	0686-1535	1
R3	fxd, comp, 510, 5%, $\frac{1}{2}$ W	1	EB-5115	01121	0686-5115	1
R4	Not Assigned					
R5	fxd, comp, 3K, 5%, $\frac{1}{2}$ W	1	EB-3025	01121	0686-3025	1
R6	fxd, comp, 1K, 5%, $\frac{1}{2}$ W	2	EB-1025	01121	0686-1025	1
R7	fxd, comp, 1.2K, 5%, $\frac{1}{2}$ W	2	EB-1225	01121	0686-1225	1
R8	fxd, comp, 8.2K, 5%, $\frac{1}{2}$ W	5	EB-8225	01121	0686-8225	1
R9	fxd, comp, 750, 5%, $\frac{1}{2}$ W	2	EB-7515	01121	0686-7515	1
R10	fxd, comp, 6.2K, 5%, $\frac{1}{2}$ W	1	EB-6225	01121	0686-6225	1
R11,12	fxd, comp, 8.2K, 5%, $\frac{1}{2}$ W		EB-8225	01121	0686-8225	
R13	fxd, comp, 1.2K, 5%, $\frac{1}{2}$ W		EB-1225	01121	0686-1225	
R14	fxd, comp, 8.2K, 5%, $\frac{1}{2}$ W		EB-8225	01121	0686-8225	
R15	fxd, comp, 5.1K, 5%, $\frac{1}{2}$ W	3	EB-5125	01121	0686-5125	3
R16	fxd, comp, 8.2K, 5%, $\frac{1}{2}$ W		EB-8225	01121	0686-8225	
R17	fxd, comp, 750, 5%, $\frac{1}{2}$ W		EB-7515	01121	0686-7515	
R18	fxd, comp, 1K, 5%, $\frac{1}{2}$ W		EB-1025	01121	0686-1025	
R19	fxd, comp, 10K, 5%, $\frac{1}{2}$ W	3	EB-1035	01121	0686-1035	1
R20	Not Assigned					
R21	fxd, comp, 5.1K, 5%, $\frac{1}{2}$ W		EB-5125	01121	0686-5125	
R22	fxd, comp, 1.5K, 5%, $\frac{1}{2}$ W		EB-1525	01121	0686-1525	
R23	fxd, comp, 5.1K, 5%, $\frac{1}{2}$ W		EB-5125	01121	0686-5125	
R24	fxd, comp, 5.6K, 5%, $\frac{1}{2}$ W	1	EB-5625	01121	0686-5625	1
R25	fxd, comp 100, 5%, $\frac{1}{2}$ W	1	EB-1015	01121	0686-1015	1
R26	fxd, comp, 5.3K, 5%, $\frac{1}{2}$ W	1	EB-4325	01121	0686-4325	1
R27	fxd, comp, 1.6K, 5%, $\frac{1}{2}$ W	1	EB-1625	01121	0686-1625	1
R28	fxd, comp, 18K, 5%, $\frac{1}{2}$ W	1	EB-1835	01121	0686-1835	1
R29	fxd, comp, 62, 5%, $\frac{1}{2}$ W	1	EB-6205	01121	0686-6205	1
R30	fxd, comp, 200, 5%, $\frac{1}{2}$ W	1	EB-2015	01121	0686-2015	1

Table 6-4. Replaceable Parts

REF. DESIG.	DESCRIPTION	QTY	MFR. PART NO.	MFR. CODE	HP PART NO.	RS
A3R31	fxd, comp, 10K, 5%, 1/2W		EB-1035	01121	0686-1035	
R32	fxd, comp, 30, 5%, 1/2W	3	EB-3005	01121	0686-3005	1
R33	fxd, comp, 10K, 5%, 1/2W		EB-1035	01121	0686-1035	
R34	fxd, comp, 30, 5%, 1/2W		EB-3005	01121	0686-3005	
R35,36	fxd, comp. 330, 5%, 1/2W	2	EB-3315	01121	0686-3315	1
R37-42	fxd, comp. 39, 5%, 1/2W	6	EB-3905	01121	0686-3905	1
R43,44	fxd, comp. 360, 5%, 1/2W		EB-3615	01121	0686-3615	
R45-48	fxd, ww, 1, 5%, 5W	6	243E	56289	0811-1340	1
R49	Not Assigned					
R50,51	fxd, ww, 1, 5%, 5W		243E	56289	0811-1340	1
R52	Not Assigned					
R53	fxd, comp. 30, 5%, 1/2W		EB-3005	01121	0686-3005	
R54	fxd, comp. 47, 5%, 1/2W	1	EB-4705	01121	0686-4705	1
R55	fxd, comp. 10, 5%, 1/2W	1	EB-1005	01121	0686-1005	1
R56-65	Not Assigned					
R66	fxd, comp. 160K, 5%, 1/2W	1	EB-1645	01121	0686-1645	1
VR1,2	Diode, zener 28.7Vdc	2	SZ11213-272	04713	1902-0572	2
A4	Power Module (includes slide, switch and fuse)			28480	5060-1189	
F1	Fuse, 1A 250V Slo-Blo	1	MDX-1A	71400	2110-0007	2
A5	Front Panel – Electrical					
DS1	Indicator Lamp (LINE)	1		28480	2140-0037	1
DS2	Indicator, Light Emitting Diode (CURRENT MODE)	1		28480	1990-0325	1
M1	Voltmeter, Dual Range DC or AC (± 2.4 , ± 24 Vdc or 1.6, 16V rms)	1		28480	1120-1371	1
M2	Ammeter Dual Range DC or AC (± 0.24 , ± 2.4 A or 0.16, 1.6A rms)	1		28480	1120-1379	1
R1	var, ww, dual ganged 15K-15K (CURRENT Control)	1		28480	2100-3271	1
R2	var, ww, 25K (VOLTAGE Control)	1		28480	2100-3272	1
S1	Switch, Toggle SPDT 5A (LINE Switch)	1		28480	3101-1605	1
S2	Switch, Rotary, 3 Sections (RANGE/MODE Selection Switch)	1		28480	3100-1942	1
A6	Heat Sink Assembly – Electrical					
Q1-4	Power NPN Si.	4	2N3715	04713	1854-0264	4
TB1-3	Terminal Block	3		28480	0360-1766	1
W1,2	Ribbon Cable Assembly	2		28480	5060-9662	1
	Chassis – Electrical					
C1,2	fxd, mylar, 1 μ F, 220Vac	2	439P1059220	56289	0160-3679	1
C3	fxd, cer., .1 μ F, 500V	1	41C92B5-CDH	56289	0160-0269	1
T1	Transformer, Power	1		28480	06825-80091	1

Table 6-4. Replaceable Parts

REF. DESIG.	DESCRIPTION	TQ	MFR. PART NO.	MFR. CODE	HP PART NO.	RS
	A1 Interconnect and Power Supply Board – Mechanical Heat Dissipator (Q1, Q3)	2	NF-207	05820	1205-0033	
	A3 Power Amplifier Board – Mechanical Heat Dissipator (Q6, Q9-Q11) Heat Dissipator (Q14-Q19)	4 6	NF-207 2227-B	05820 13103	1205-0033 1205-0206	
	Heat Sink Assembly – Mechanical Bushing Insulator (Q1-Q4) Insulator, Mica (Q1-Q4) Chassis Rear Heat Sink Barrier Strip Board Assembly Heat Sink Board Assembly	4 4 1 1 1 1		28480 28480 28480 28480 28480 28480	0340-0795 0340-0174 5000-9369 5020-8401 5060-9663 06826-60023	
	Front Panel – Mechanical Bezel, Meter Control Panel Output Panel Foot Assembly Insulator, Binding Post (Black) Insulator, Binding Post (Red) Knob (VOLTAGE Control, CURRENT Control, VOLTAGE METER switch, CURRENT METER switch) Knob (MODE select) Knob (RANGE select) Clip Retainer Ring Lamp Holder, Clear Lamp Holder, Black Binding Post (Red) Binding Post (Black) Tilt Stand	2 1 1 1 2 8 4 1 1 4 4 1 1 4 1 1 1		28480 28480 28480 28480 28480 28480 28480 28480 28480 28480 28480 28480 28480 28480 28480 28480 28480	4040-0483 06825-60001 5000-9366 5060-0728 0340-0733 0340-0734 0340-1099 0370-1100 0370-1125 1400-0532 1400-0540 5040-0234 5040-0305 1510-0094 1510-0522 1490-0032	1
	Chassis – Mechanical Cover, Top Cover, Bottom Cover, Side Chassis Rear Panel, Bottom Foot Assembly Jumper, Barrier-Strip Standoff 8-32 x .875 Cover Barrier Strip 6 x 11 Frame Assembly	1 1 2 1 1 1 9 2 1 2		28480 28480 28480 28480 28480 28480 28480 28480 28480 28480	5000-3090 5000-9368 5000-9432 5000-9364 5000-9345 5060-0728 0360-0523 0380-0849 5000-9356 5060-0703	
	Miscellaneous Fuse .5A 250V Slo-Blo Power Card Packing Carton Floater Pad, Carton	1 1 1	MDL-½	71400 28480 28480 28480	2110-0202 8120-1348 9211-1196 9220-1409	
	Option 007: 10-Turn VOLTAGE Control var, ww 20K, 5%, 2W, linear, 10-turn			28480	2100-1867	

SECTION VII CIRCUIT DIAGRAMS

7-1 INTRODUCTION

7-2 This section contains the circuit diagrams necessary for the operation and maintenance of BPS/A Model 6825A.

7-3 SIMPLIFIED SCHEMATIC DIAGRAM

7-4 This diagram, Figure 7-2, shows the relationship between the instrument assemblies and ties the schematic diagram sheets together.

7-5 COMPONENT LOCATION ILLUSTRATIONS

7-6 The component location diagrams show the physical location of parts mounted on each assembly. They are in-

cluded on the schematic diagrams where they apply or on the rear of the previous schematic. Thus, the schematic diagram is unfolded to the right and component location diagram is unfolded to the left.

7-7 SCHEMATIC DIAGRAMS

7-8 The schematic diagram, Figure 7-2, consists of two sheets. Sheet 1 illustrates the Output Power Amplifier Circuits and Sheet 2 illustrates the Voltage and Current Control Circuits.

7-9 Test points (encircled numbers) appear on the schematics. These points coincide with the test points on the component location diagrams and are referred to in the text.

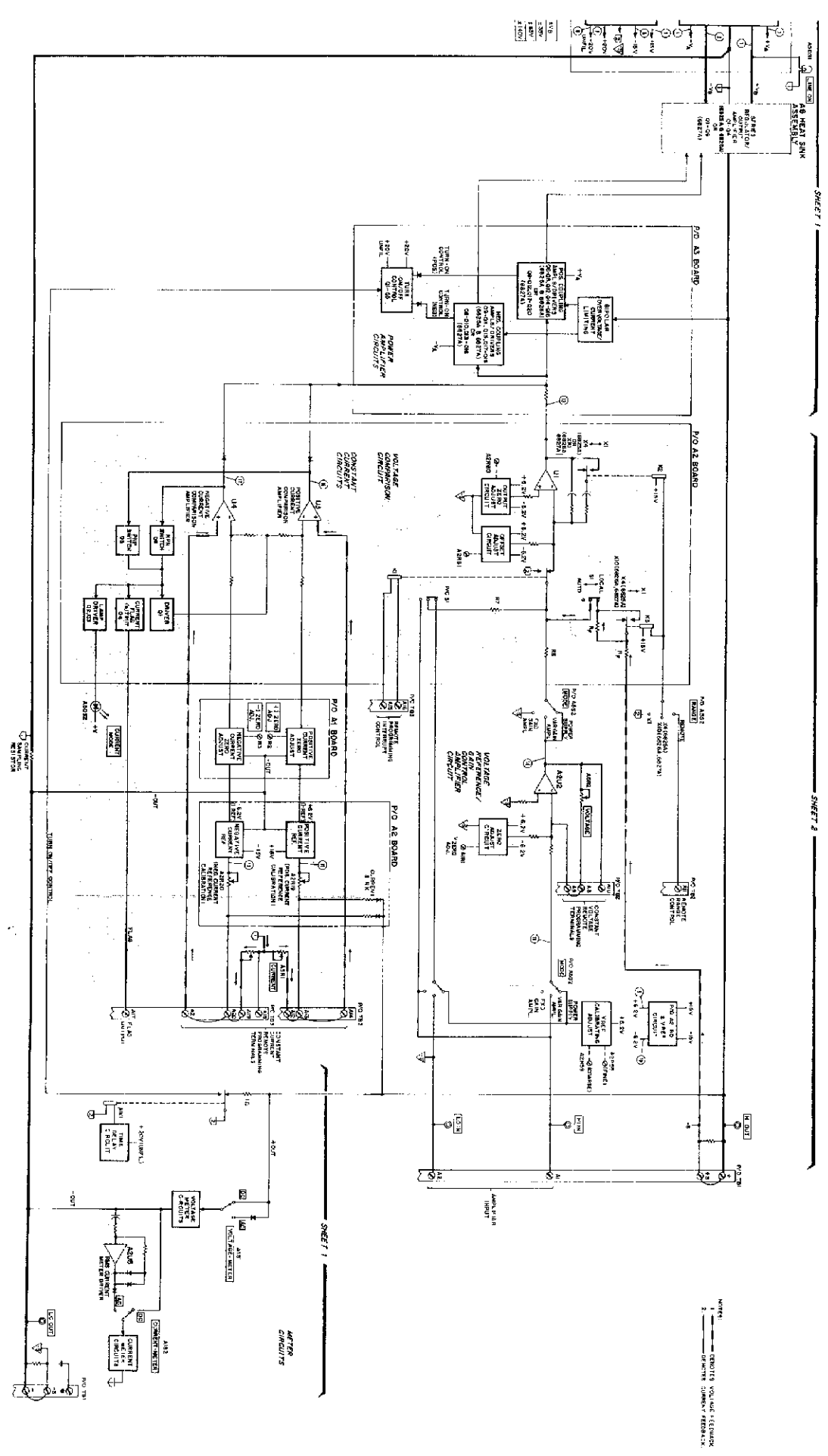
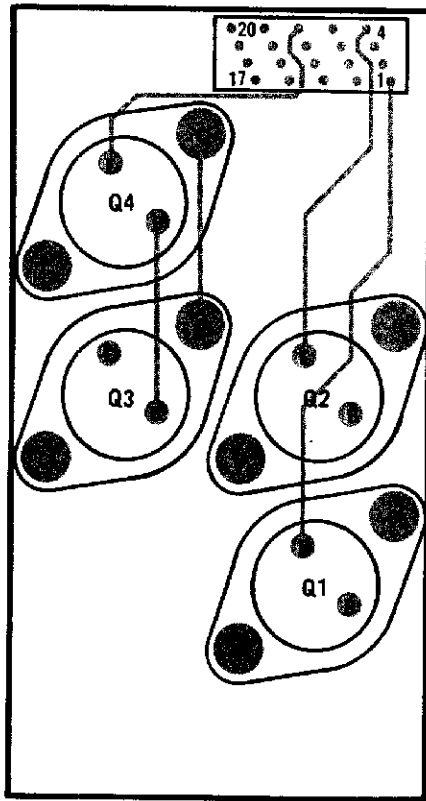
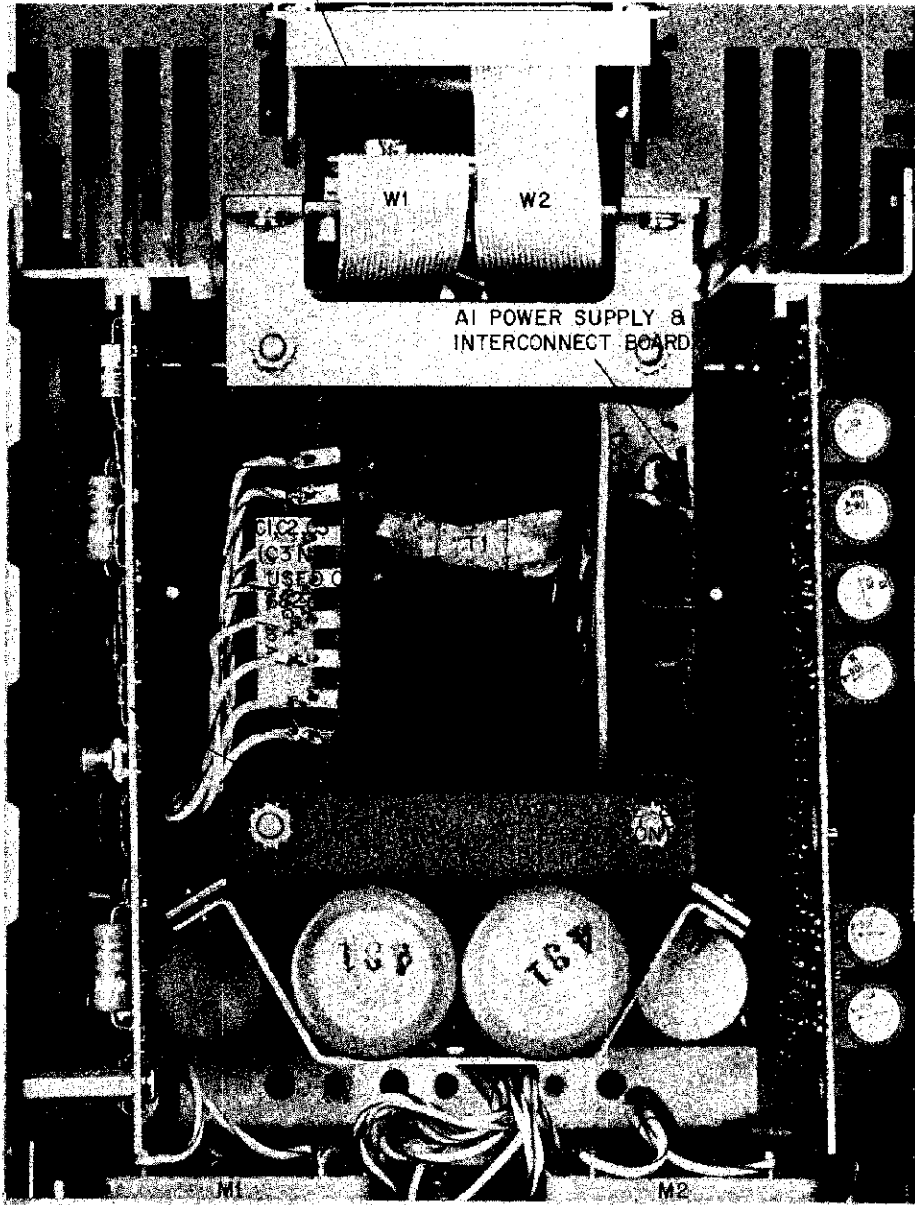

Figure 7-1. Simplified Schematic Diagram



Heat Sink Board Assembly, Component Location

HEAT SINK BOARD ASSEMBLY
Q1 - Q4 (6825A, 6826A)
Q1 - Q6, R1 - R3 (6827A)



Top View, Component Location

* MODEL 6825A USES A
DIFFERENT TYPE DIODE

** R12, R15 JUMPERED ON 6825A
CR19 IS JUMPERED ON 6825A, 6826A
R22 IS JUMPERED ON 6827A

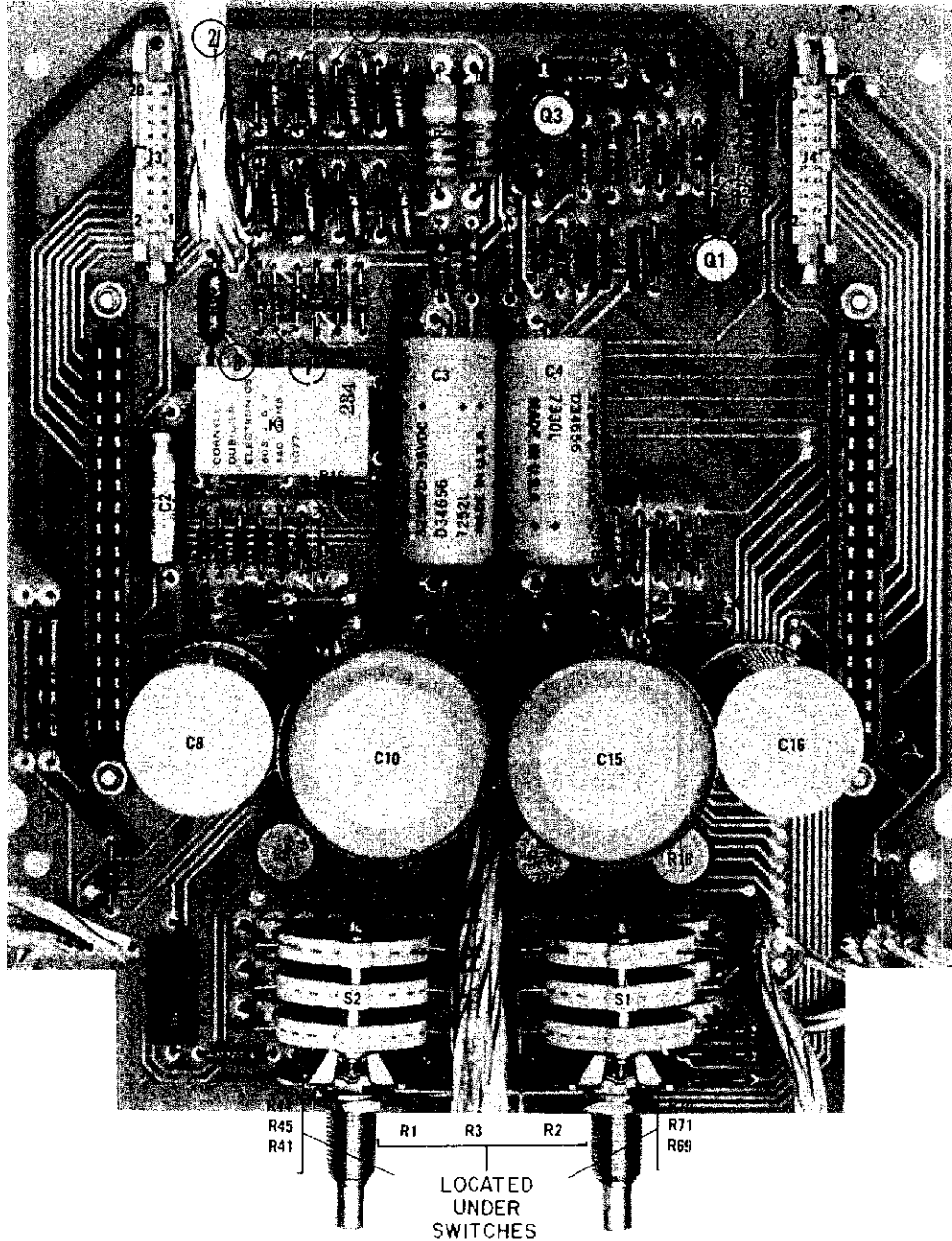

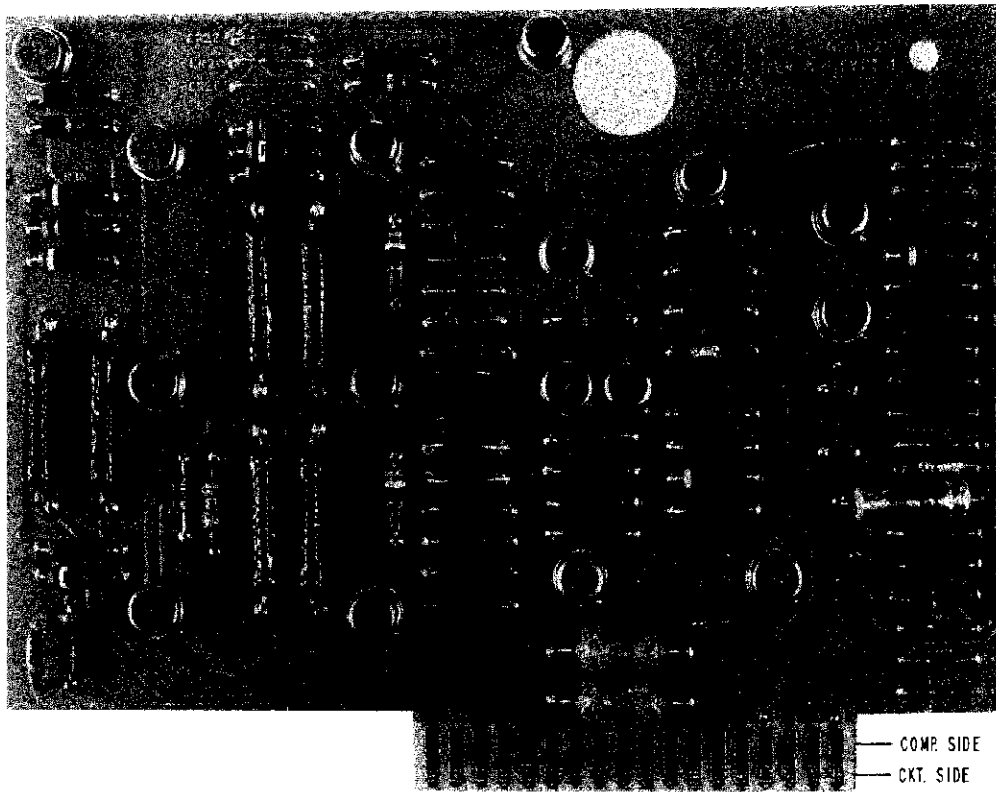

A1 Power Supply and Interconnect Board, Component Location



A3 Amplifier Board, Component Location

NOTES:

1. ALL RESISTORS ARE IN OHMS, 1/2W, 5% UNLESS OTHERWISE INDICATED.
2. ALL 1/8W AND 1/4W RESISTORS ARE 1%, UNLESS OTHERWISE INDICATED
3. ALL CAPACITORS ARE IN MICROFARADS, UNLESS OTHERWISE INDICATED.
4.  DENOTES FRONT PANEL MARKING.
5.  DENOTES VOLTAGE FEEDBACK
6.  DENOTES CURRENT FEEDBACK.
7. PIN LOCATIONS FOR TRANSISTORS ARE AS FOLLOWS:

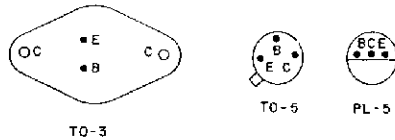

(ALL BOTTOM VIEWS)

8. PIN LOCATIONS FOR INTEGRATED CIRCUITS A2U1-A2U5 ARE AS FOLLOWS:



(BOTTOM VIEW)

9. THE LOCAL/AUTO SWITCH, LOCATED INSIDE THE UNIT ON BOARD A2, IS ACCESSIBLE BY REMOVING THE RIGHT SIDE COVER OR TOP COVER. FOR NORMAL OPERATION, THE SWITCH MUST BE LEFT IN THE LOCAL POSITION (PUSHED TO THE RIGHT OR TO REAR OF UNIT). THE AUTO POSITION (PUSHED TO LEFT OR FRONT OF UNIT) IS USED ONLY DURING AUTO-SERIES OR AUTO-PARALLEL OPERATION OF TWO OR MORE UNITS.
10. JUMPER A2W1 IS REMOVED FOR OPEN COLLECTOR OPERATION. NOTE THAT THIS CIRCUIT IS REFERENCED TO  COMMON WHICH IS CONNECTED TO THE -S TERMINAL.

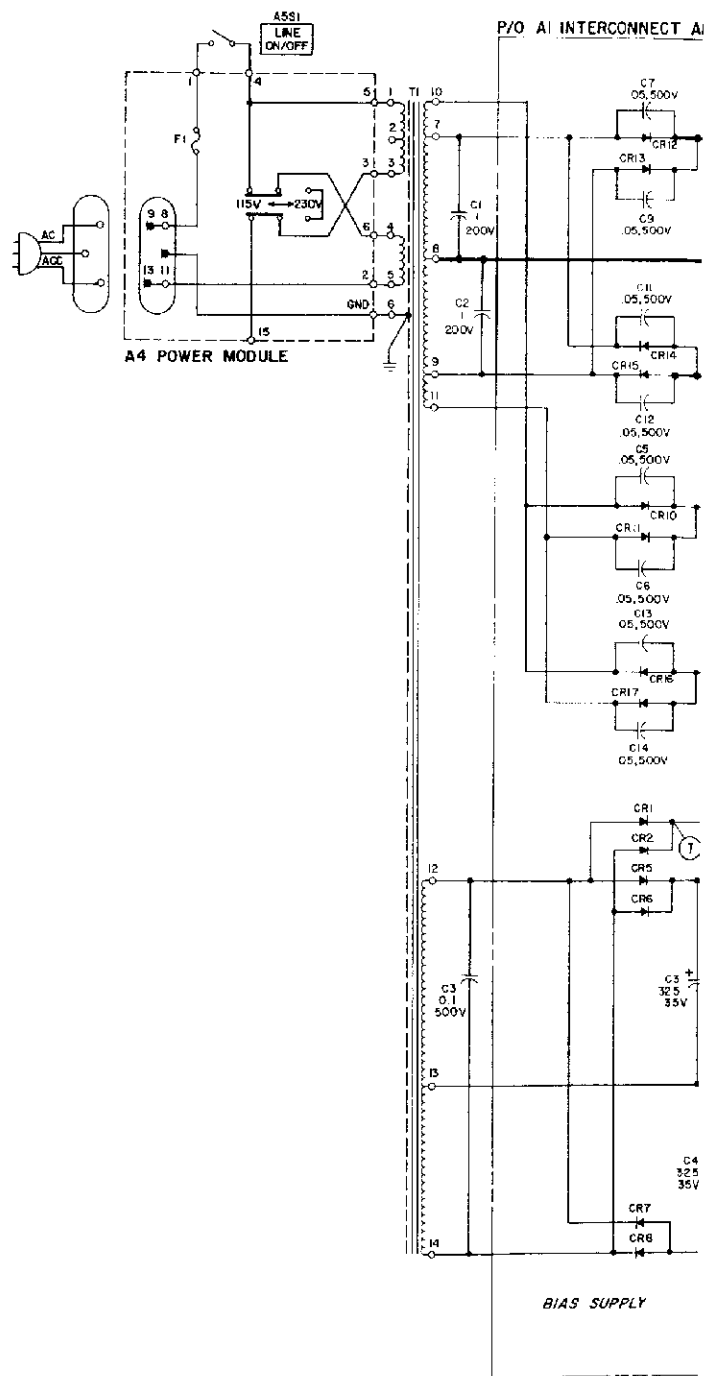

BY
CH
THE
1-
JIT

P/O AI INTERCONNECT AND POWER SUPPLY BOARD

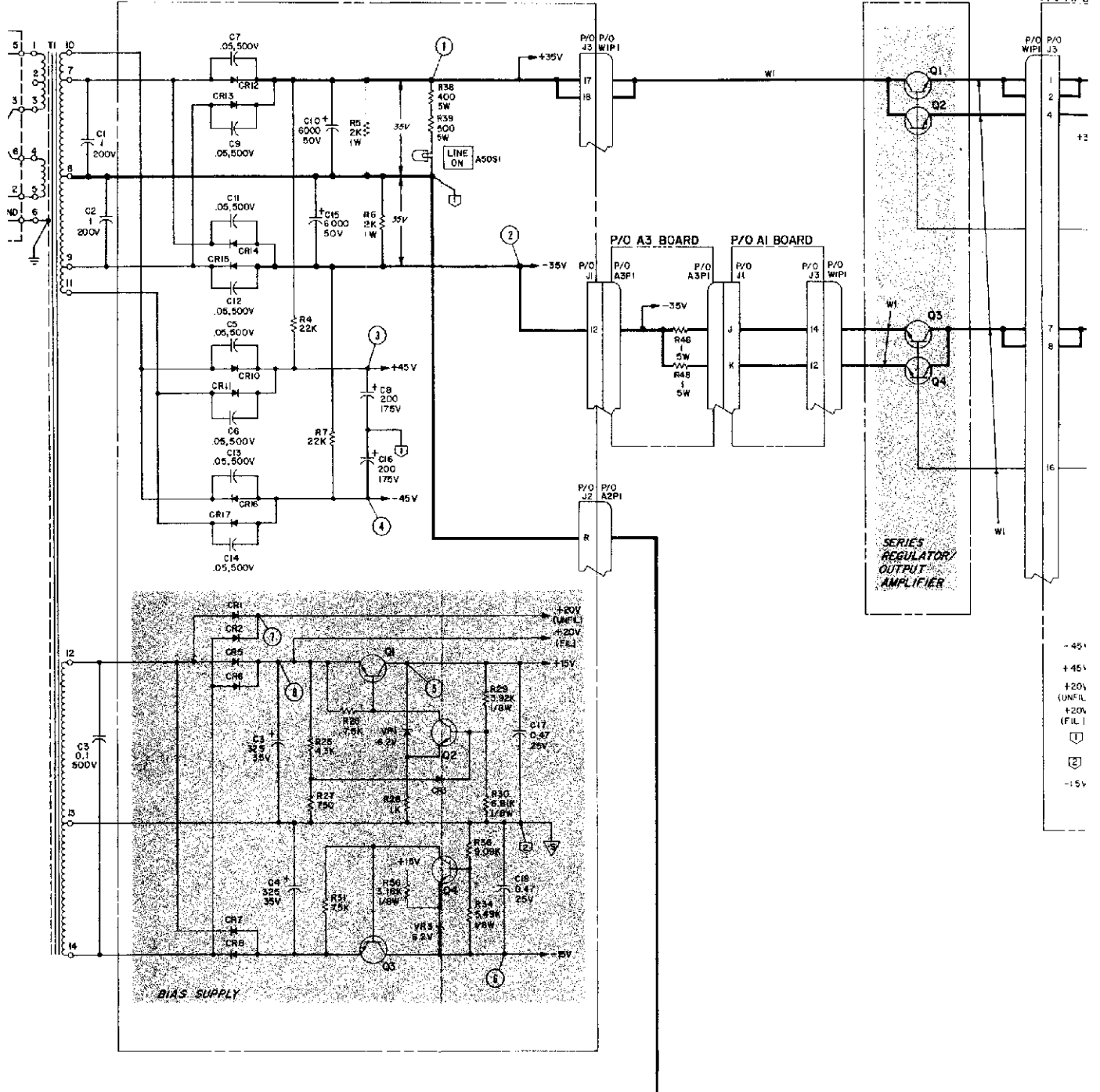

1 BOARD P/O A3 POWER AMPLIFIER 80.

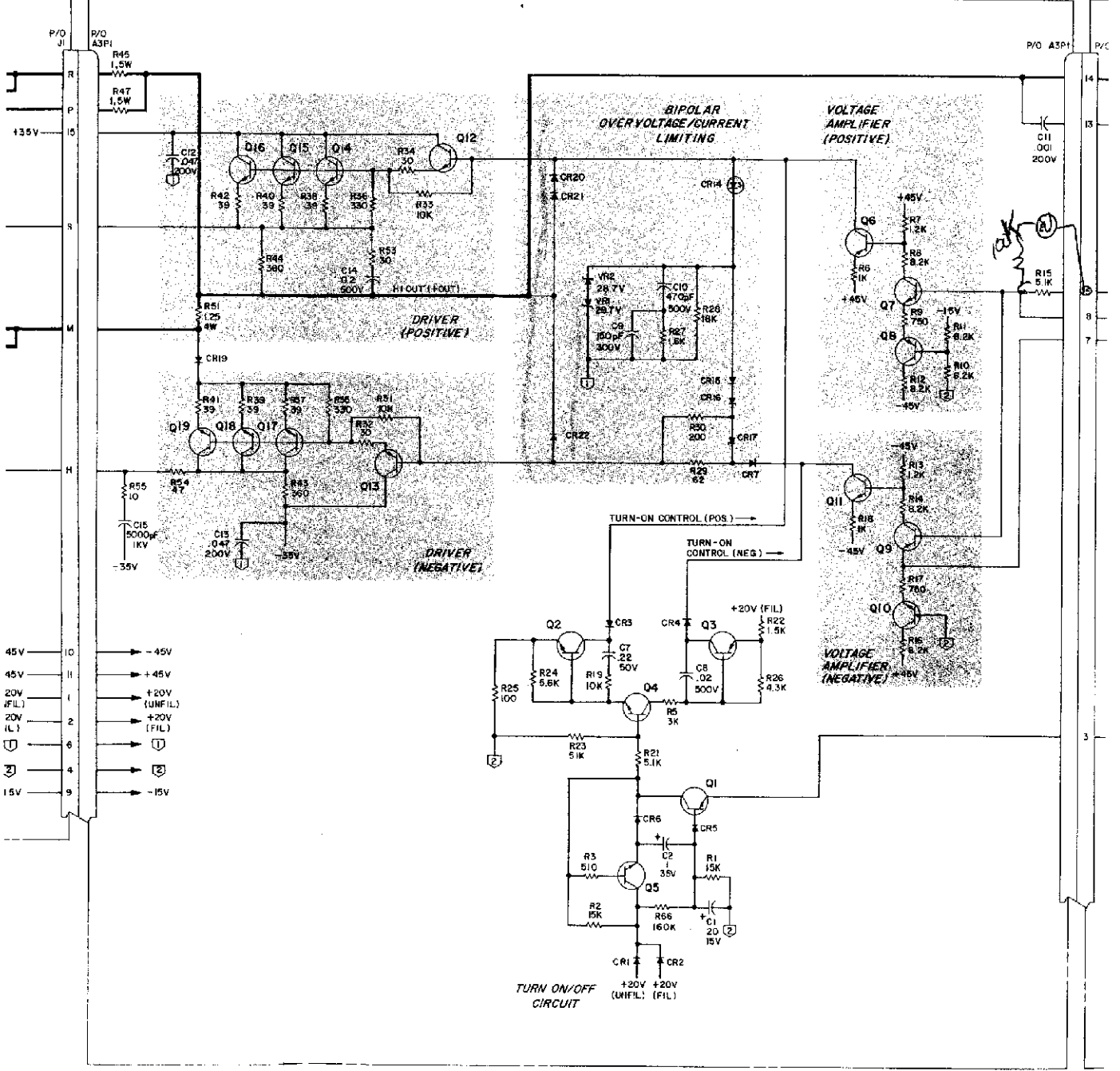

P/O A1 INTERCONNECT AND POWER SUPPLY BD.

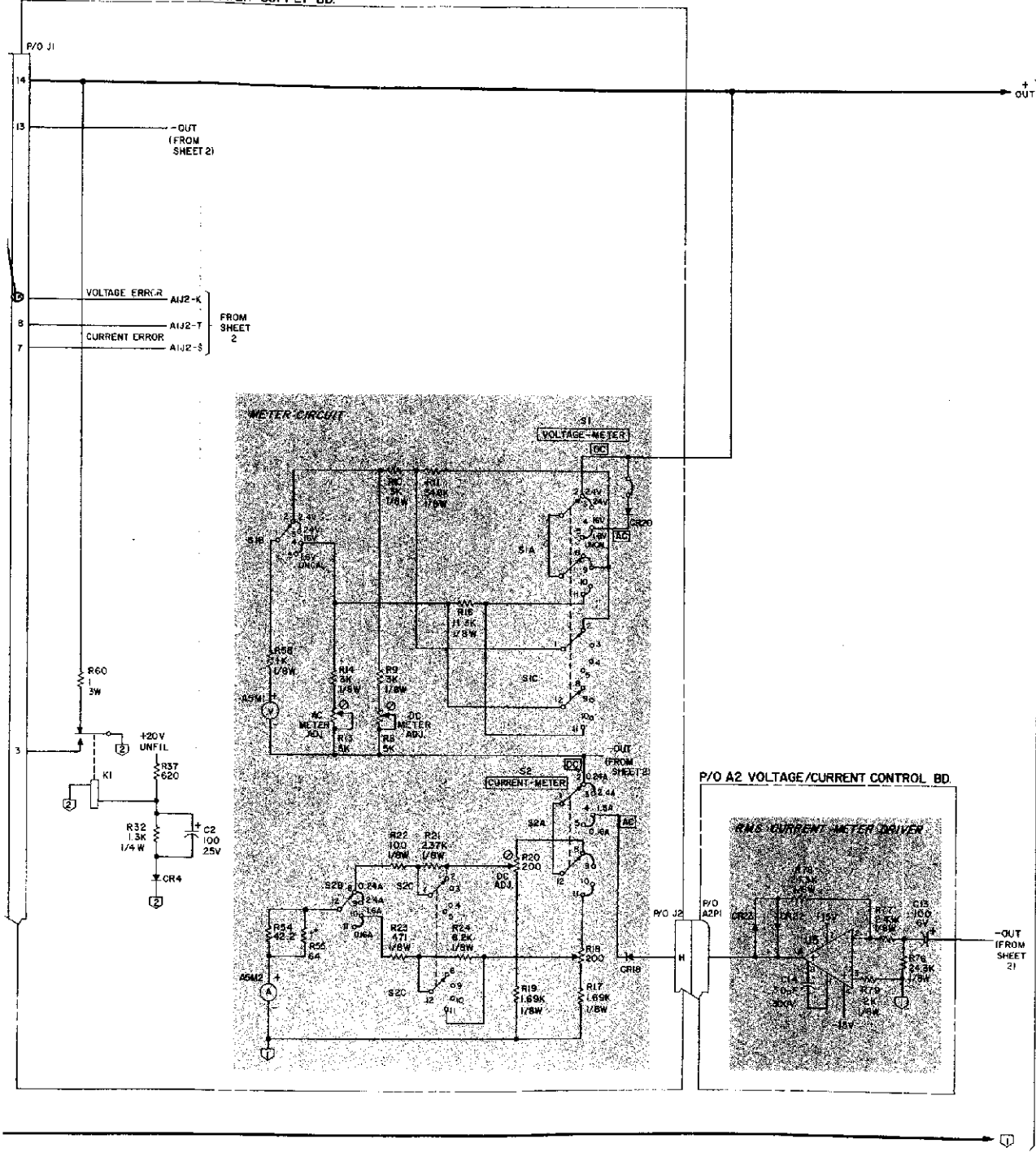

SHEET 2

Figure 7-2 (Sheet 1). Output Power Amplifier Circuits, Schematic Diagram

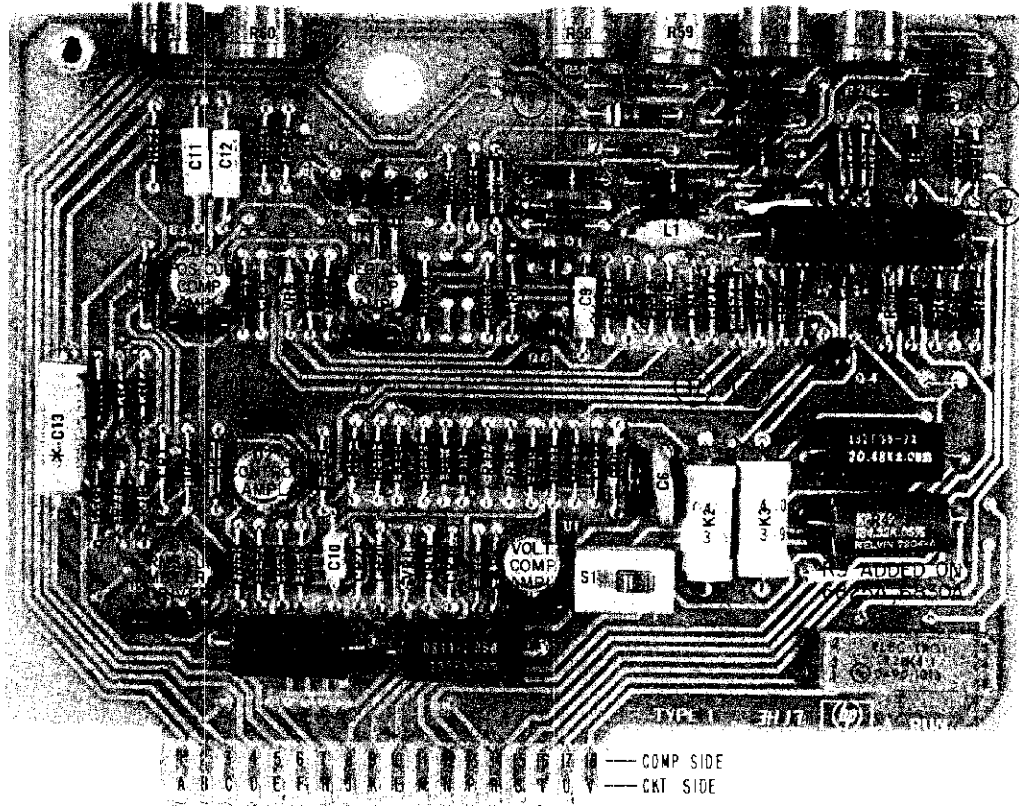

- ** JUMPERED ON 6825A, 6826A, 6830A, 6831A
- * NOT USED ON 6830A, 6831A, 6832A

A2 Voltage and Current Control Board, Component Location

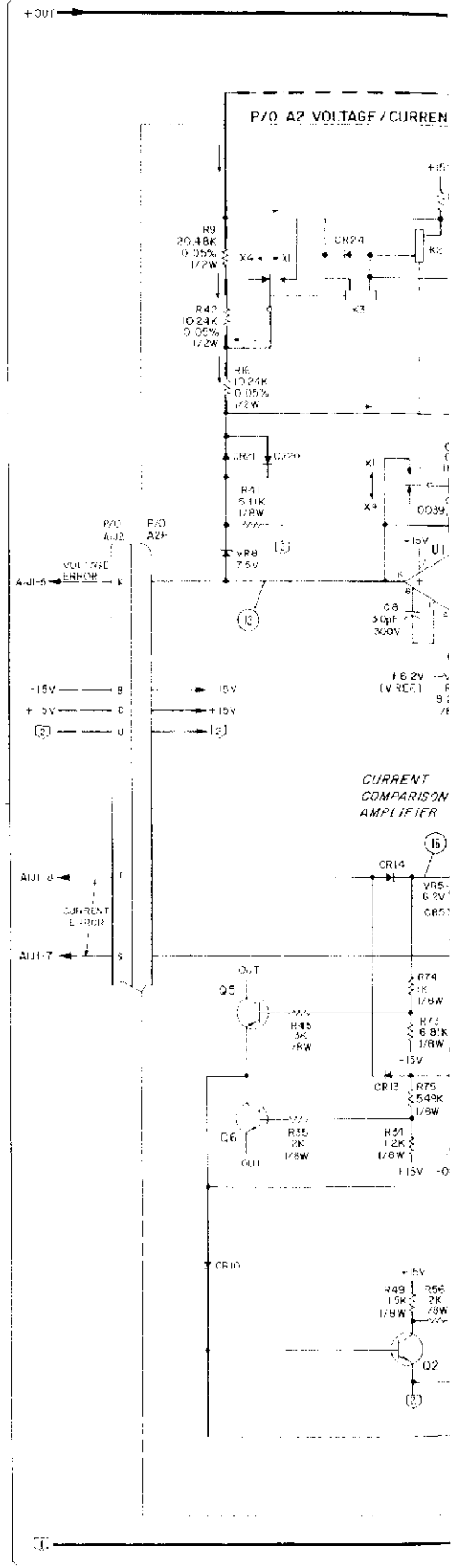

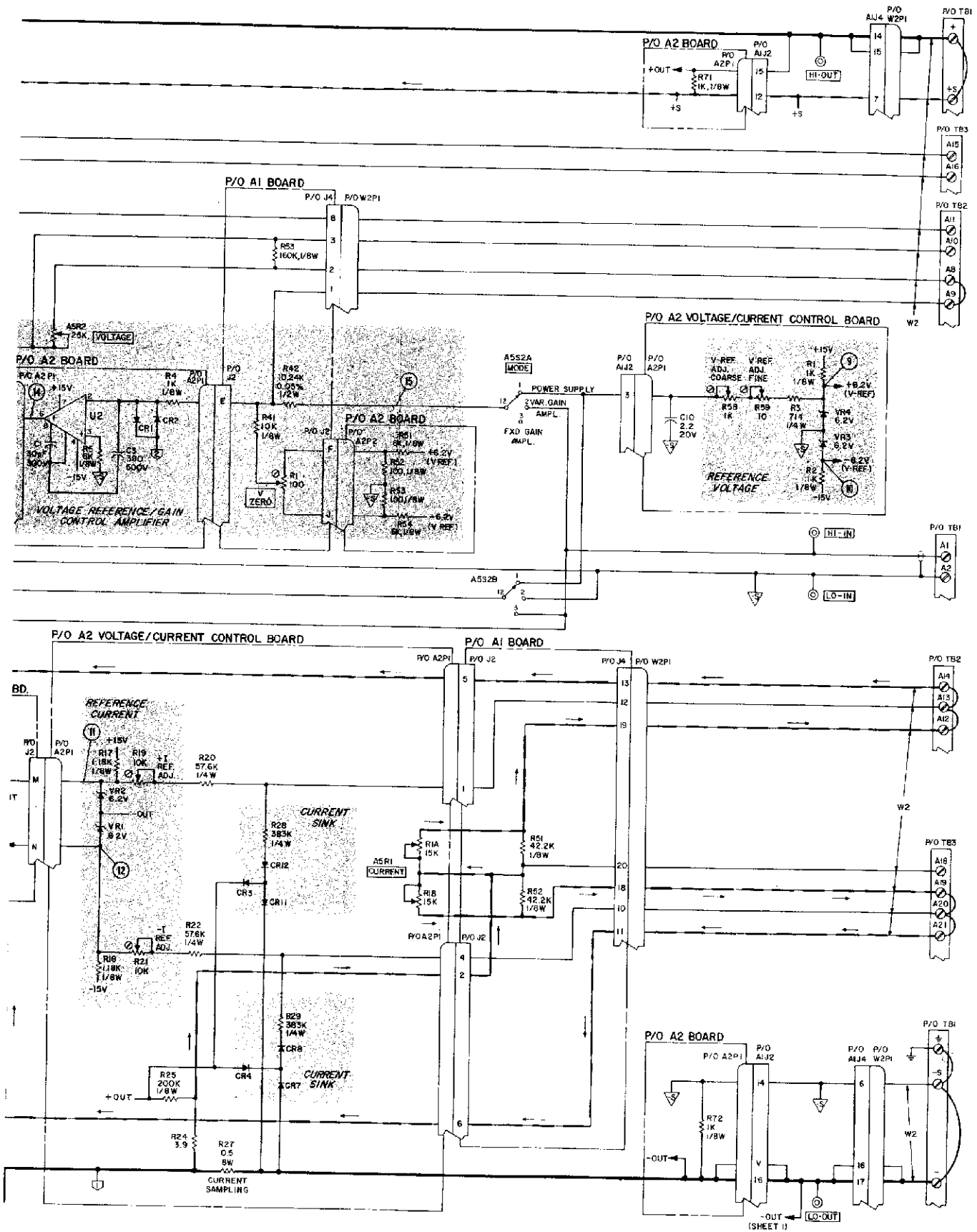

Figure 7-2 (Sheet 2). Voltage and Current Control Circuits, Schematic Diagram